

Structured ALE Workshop

Hao Chen

Livermore Software Tech Corp

June 15 2016

Me

- Hao Chen, hao@lstc.com, 925-245-4552
- 1997-2002, Northwestern University, Ph.D., Computational Mechanics
- Jan 2003, joined LSTC, ALE and FSI
- Mar 2015, the new Structured ALE solver

Structured ALE solver

- <http://ftp.lstc.com/anonymous/outgoing/hao/sale>
- Jan 2015, an automated mesh generator
- Mar 2015, started implementation
- Nov 2015, debuted in LS-DYNA China Conf.
- June 2016, Detroit LS-DYNA Conference, Training Class

ALE – Arbitrary Lagrangian Eulerian

- ALE = Eulerian Method + Mesh Motion
- Solving Momentum Equation
 - Lagrange timestep
 - Advection timestep (remapping)
- Multi-material Formulation
 - Element volume fraction
 - 1 strain rate, multiple stresses per element
 - Interface reconstruction
- FSI – Fluid structure Interaction
 - Structure mesh/ ALE mesh: separate and overlapping

ALE Applications

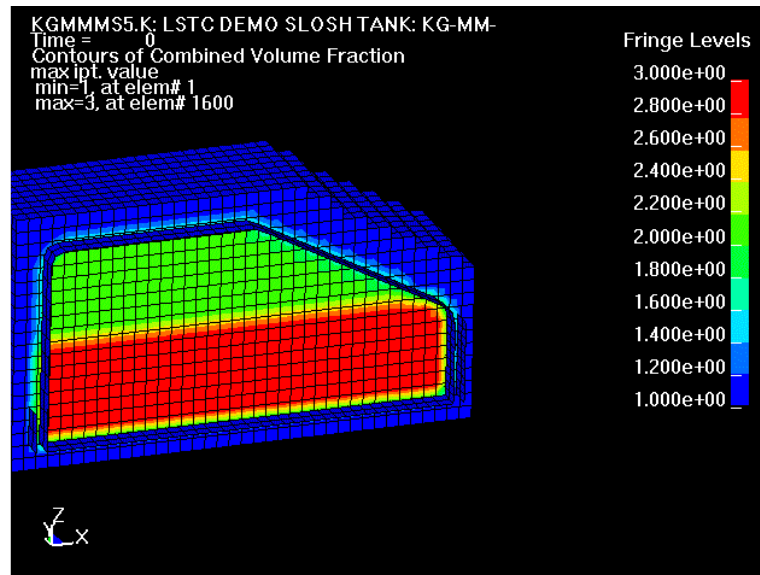
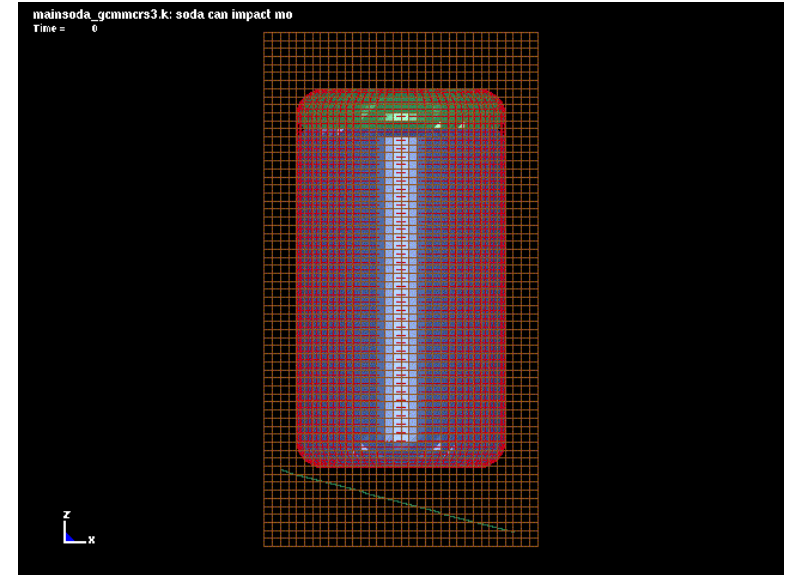
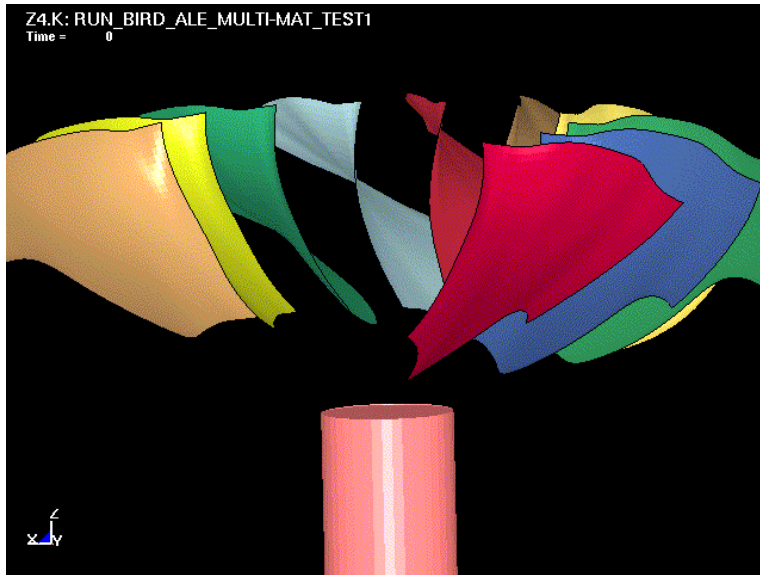

ALE Applications

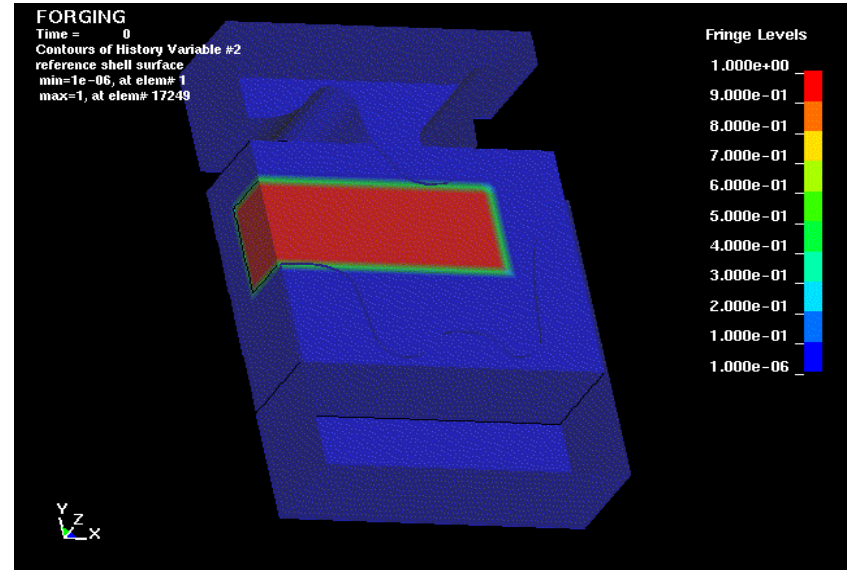
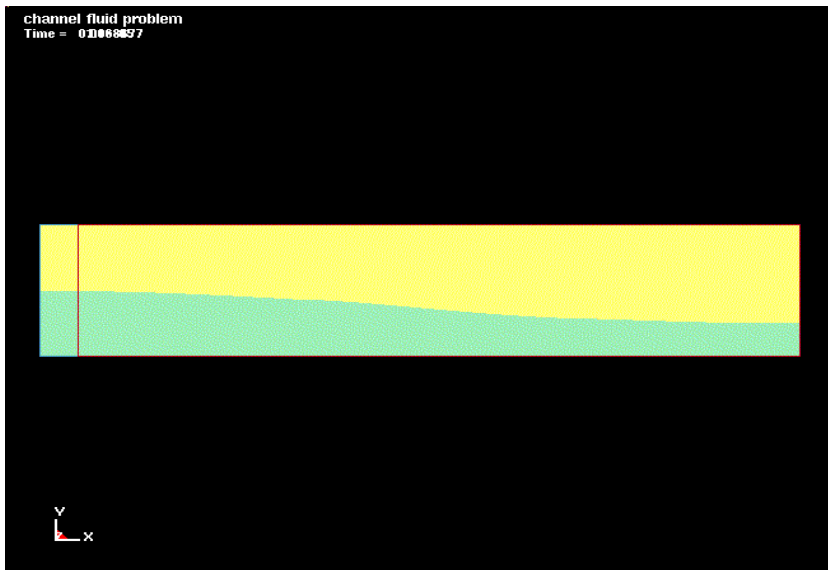
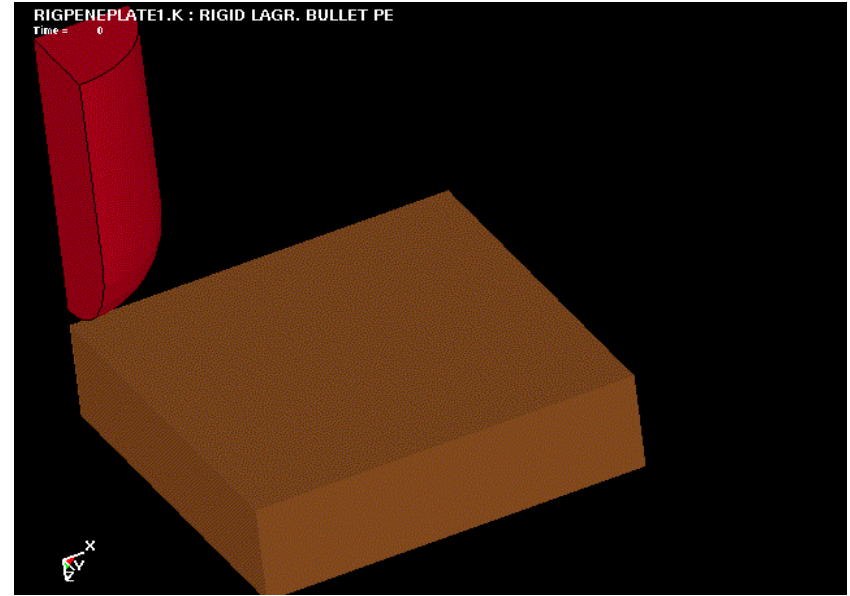
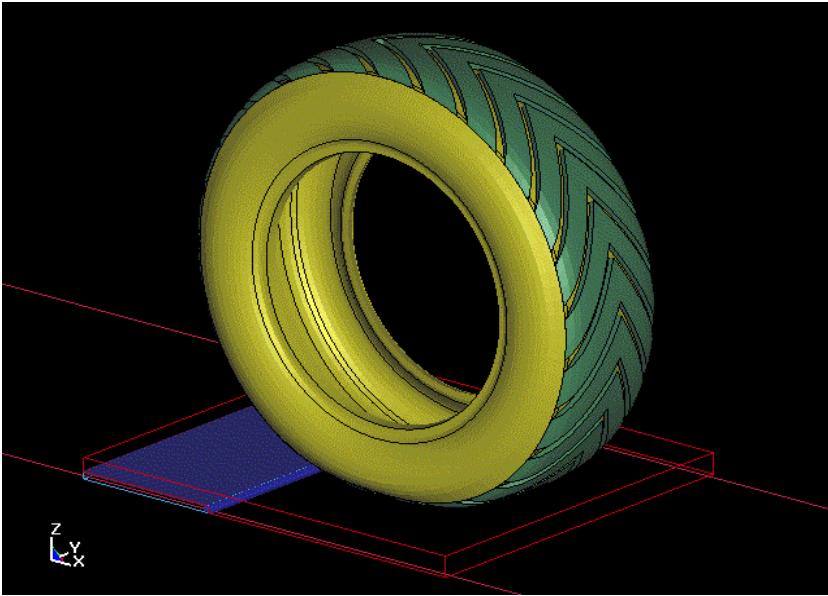

S-ALE – Structured ALE Solver

- Same theory
 - Advection (remapping)
 - Interface reconstruction
 - FSI – coupling to Lagrange structure
- Different Implementation
 - New automated mesh generation
 - A much more compact solver
 - Time saving in searching and sorting
 - Stable and user-friendly

Motivation

- S-ALE (Structured ALE) solver and ALE solver
 - Same algorithm (advection, interface reconstruction)
 - Separate coding
- Engineering applications evolved.
 - Solid → fluids
 - Single material → multiple materials
 - Conforming mesh → structured mesh
- Computing Technology evolved.
 - SMP → MPP → MPP+SMP (MPP Hybrid)
- A better user experience
 - Stable code behavior
 - Conceptually clear setup
 - Compact database

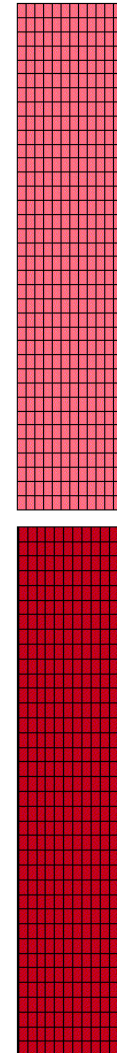

Overview

- Structured ALE mesh automatically generated
 - Smaller input deck; Easier modifications to the mesh; Less I/O time.
- Shorter calculation time
 - Sorting, searching faster and more efficient; Also more accurate.
- Less memory
 - A rewritten leaner, cleaner code using less memory to accommodate larger problems.
- SMP, MPP, MPP-Hybrid supported
 - Redesigned algorithm enabled SMP parallelization hence MPP Hybrid.
 - Enhancement on MPP efficiency

Automated Mesh Generation

- User specifies mesh spacing information along three directions
- One node for mesh origin and another three for local coordinate system

Time = 0

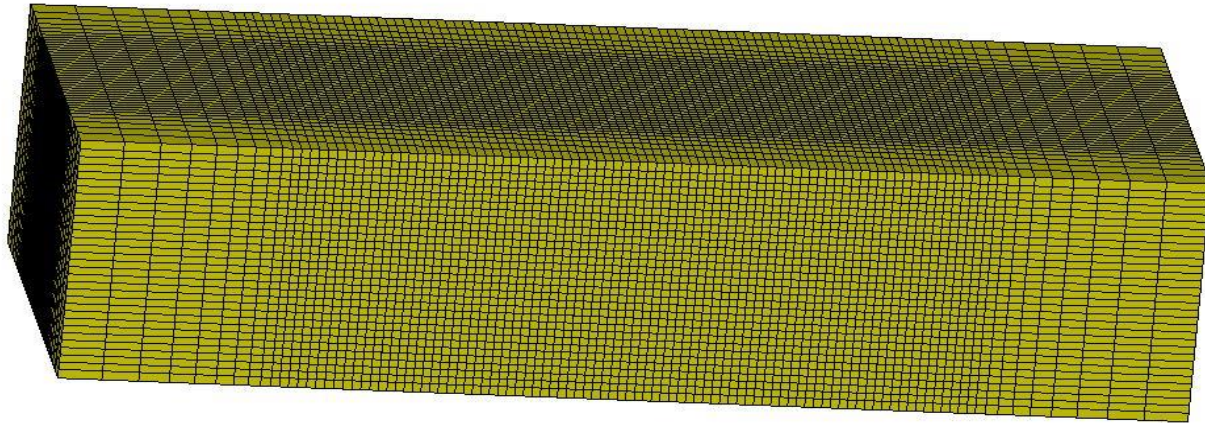

Mesh Motion

- Motion of the origin node defines translational mesh motion
- Motion of the three nodes defining the local coordinate system defines mesh rotation.

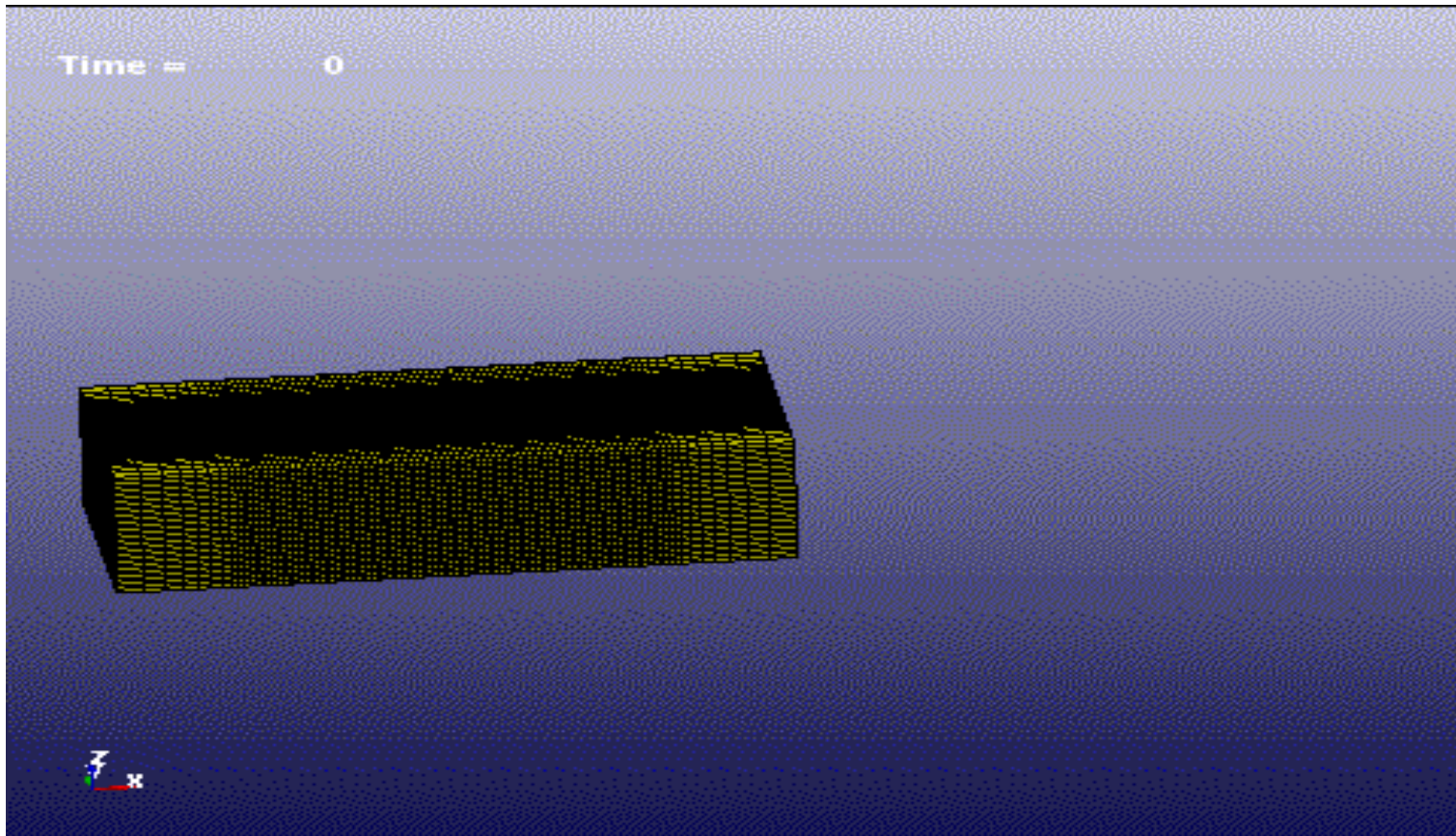

Keywords

- *ALE_STRUCTURED_MESH

*ALE_STRUCTURED_MESH					
MSHID	PID	NBID	EBID		
CPIDX	CPIDY	CPIDZ	NID0	LCSID	

- *ALE_STRUCTURED_MESH_CONTROL_POINTS

*ALE_STRUCTURED_MESH_CONTROL_POINTS					
CPID			SFO		OFF0
	NID1		X1		
	NID2		X2		

S-ALE Model Setup

- S-ALE: A straight-forward 3-step setup
 1. Mesh generation – to generate a single mesh part.
 2. Define ALE multi-materials – to define materials reside in the S-ALE mesh.
 3. Fill in the multi-materials – to fill in the S-ALE mesh with the multi-materials at the initial stage.
- Two kinds of *PART definition in S-ALE
 - Mesh PART: refers to S-ALE mesh – a collection of elements and nodes; no material info; only one mesh PART.
 - Material PART: refers to multi-materials flow inside the S-ALE mesh; no mesh info; multiple cards each defines one multi-material (*MAT+*EOS+*HOURGLASS).

S-ALE Applications

Application: Penetration – Model Description

- A long rod projectile impacting an oblique steel plate (Fugelso & Taylor 1978).
- Model dimensions from ARL-TR-2173 (Schraml & Kimsey 2000)
- Material MAT_JOHNSON_COOK+EOS_LINEAR_POLYNOMIAL, “Numerical Simulation of High-Velocity oblique Impacts of Yawed Long Rod Projectile Against Thin-Plate” (Yo-Han Yoo 2002)

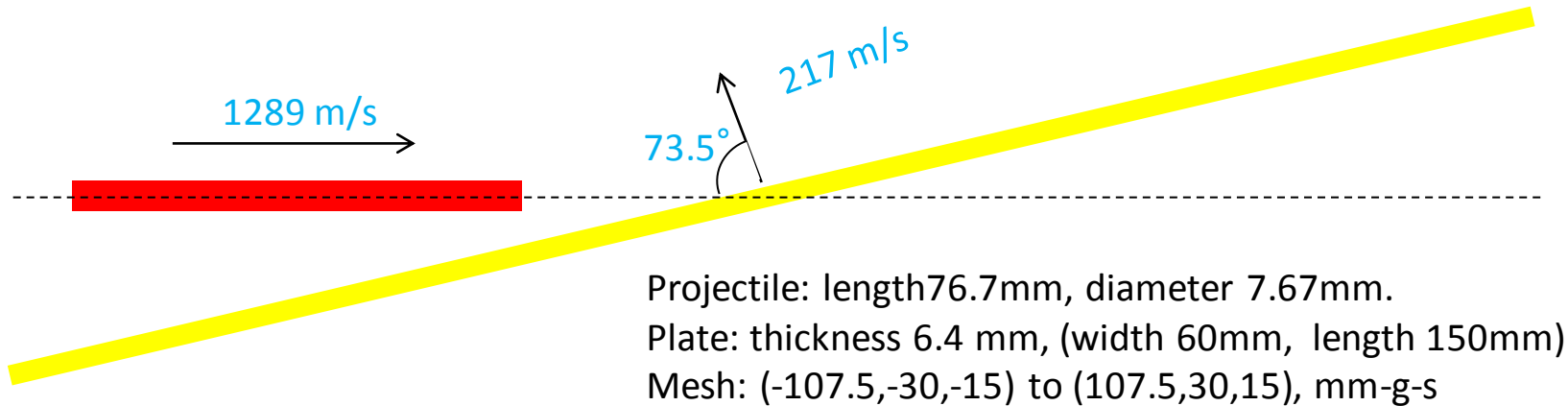

	RO	G	E	PR	A	B	N	C	M	TM	TR	C1
ROD	18.6e-3	63.7e3	165.6e3	0.3	1.079e3	1.12e3	0.25	0.007	1.00	1473	283	138.0e3
PLATE	7.87e-3	76.7e3	200.1e3	0.3	0.792e3	0.51e3	0.26	0.014	1.03	1809	283	166.7e3

Application: Penetration – Simulation

- 1mmx1mmx1mm regular HEX mesh with 387,000 elements (215x60x30)
- Simulation time of 0.04s took 7 minutes on a single thread SMP.

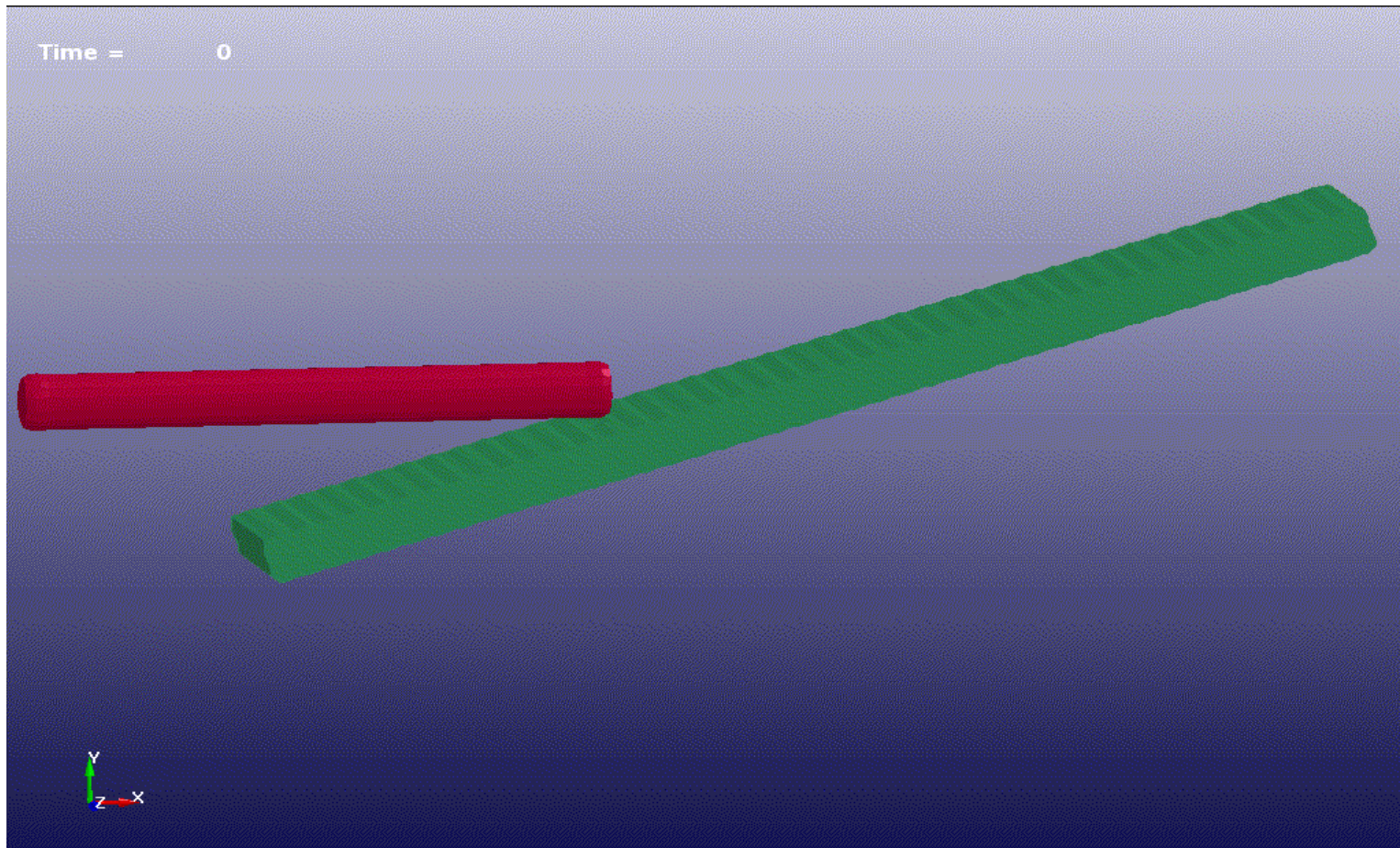

Application: Penetration – Model Setup 1

*ALE_STRUCTURED_MESH					
MSHID	PID	NBID	EBID		
1	11	100001	100001		
CPIDX	CPIDY	CPIDZ	NID0	LCSID	
1001	1002	1003			

MSHID: Mesh ID (for future use)

PID: Part ID assigned to the mesh
NO NEED to define *PART card

NBID: Starting Node ID

EBID: Starting Element ID

NID0: Origin Node ID

LCSID: Local Coordinate System ID

*ALE_STRUCTURED_MESH_CONTROL_POINTS			
1001			
	1		-107.5
	216		107.5

*ALE_STRUCTURED_MESH_CONTROL_POINTS			
1002			
	1		-30.0
	61		30.0

*ALE_STRUCTURED_MESH_CONTROL_POINTS			
1003			
	1		-15.0
	31		15.0

Application: Penetration – Model Setup 2

*ALE_MULTI-MATERIAL_GROUP			*PART				
PID	PTYPE		PID	SECID	MID	EOSID	HGID
1	1		1	1	1	1	1
3	1		3	1	2	2	1
2	1		2	1	3		1

1 to 1 correspondence

PID	MATERIAL	AMMG
1	ROD	1
3	VACUUM	2
2	PLATE	3

- *PART definitions to define multi-materials reside in S-ALE mesh; one to one correspondence.
- These PART IDs only appear in *ALE_MULTI-MATERIAL_GROUP; NOT to be used anywhere else.
- Material PARTs have neither elements nor nodes; serves as a wrapper to include *MAT+*EOS+HOURLASS

Application: Penetration – Model Setup 3

*INITIAL_VOLUME_FRACTION_GEOMETRY							
SID	IDTYP	BAMMG					
11	1	2					
TYPE	FILLOPT	FAMMG	VELX	VELY			
1	1	3	-61.631	208.06			
PID	IDTYP						
101	1						
TYPE	FILLOPT	FAMMG	VELX				
4	0	1	1289				
X0	Y0	Z0	X1	Y1	Z1	R1	R2
-103.0	0.0	0.0	-26.33	0.0	0.0	3.835	3.835

1. First set all elements in PART 11 to vacuum (AMMG2)
2. Next switch vacuum (AMMG2) inside LAG part 101 to plate (AMMG3)
3. Finally switch vacuum (AMMG2) inside a cylinder to rod (AMMG1)

Application: Penetration – Model Setup MISC

*CONTROL_ALE							
DCT	NADV	METHOD	AFAC	BFAC	CFAC	DFAC	EFAC
	1	1					
START	END	AAFAC	VFACT	PRIT	EBC	PREF	NSIDEBC

*CONTROL_TERMINATION	
ENDTIME	ENDCYCL
0.04	

*CONTROL_TIMESTEP	
DTINIT	TSSFAC
	0.600

*DATABASE_BINDARY_D3PLOT	
DT	LCDT
0.001	

Optional card: refine the mesh for better accuracy

*ALE_STRUCTURED_MESH_REFINE			
MSHID	NX	NY	NZ
1	2	2	2

Application: Penetration – Refinement

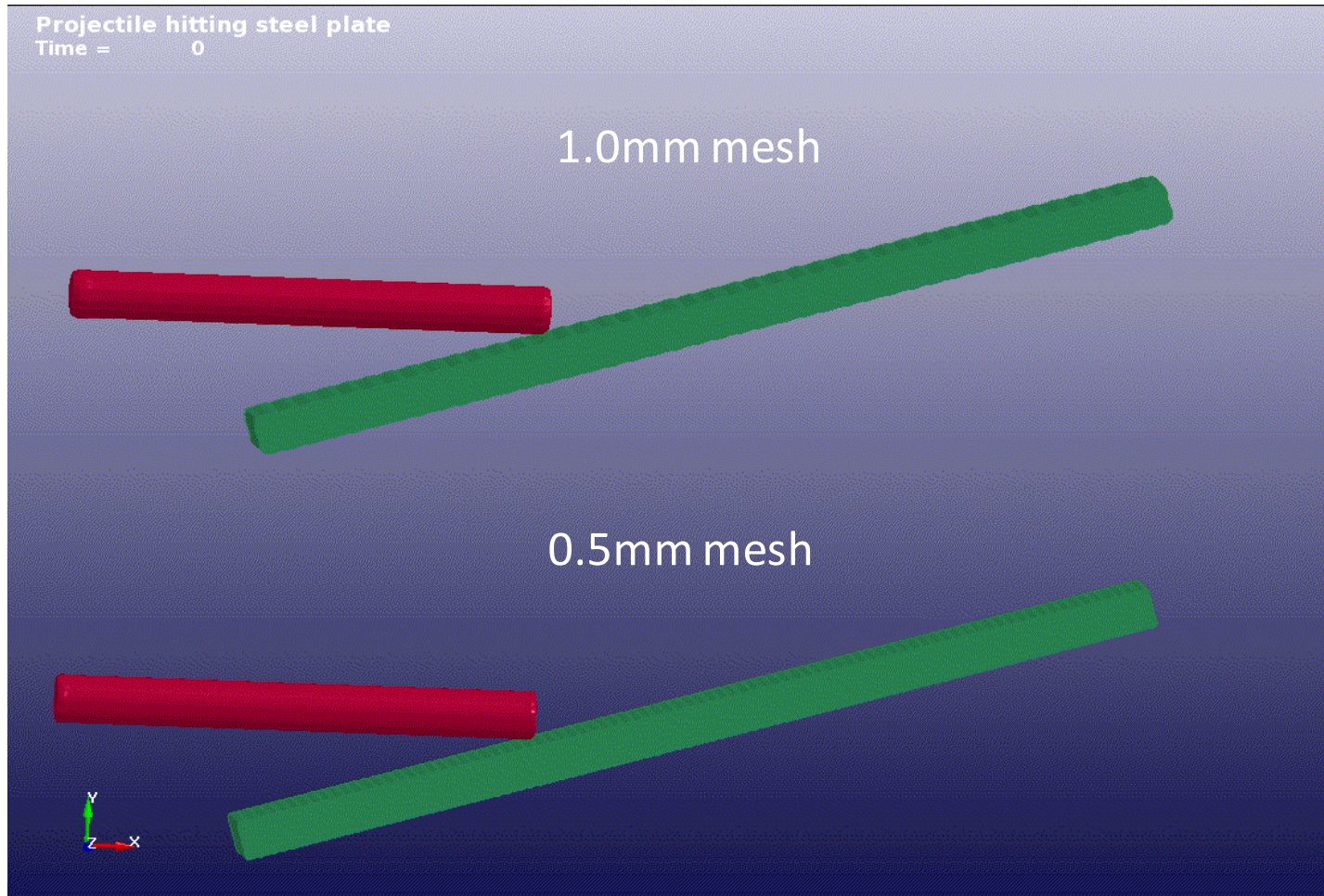

Model size: 387,000 vs. 3,096,000
Running time: 14m vs. 3h16m.

Application: Penetration – MPP Performance

NCPU	12	24	48	96	192	384
Total Time	2068	1128	680	333	176	98
S-ALE	1327	733	451	220	118	62

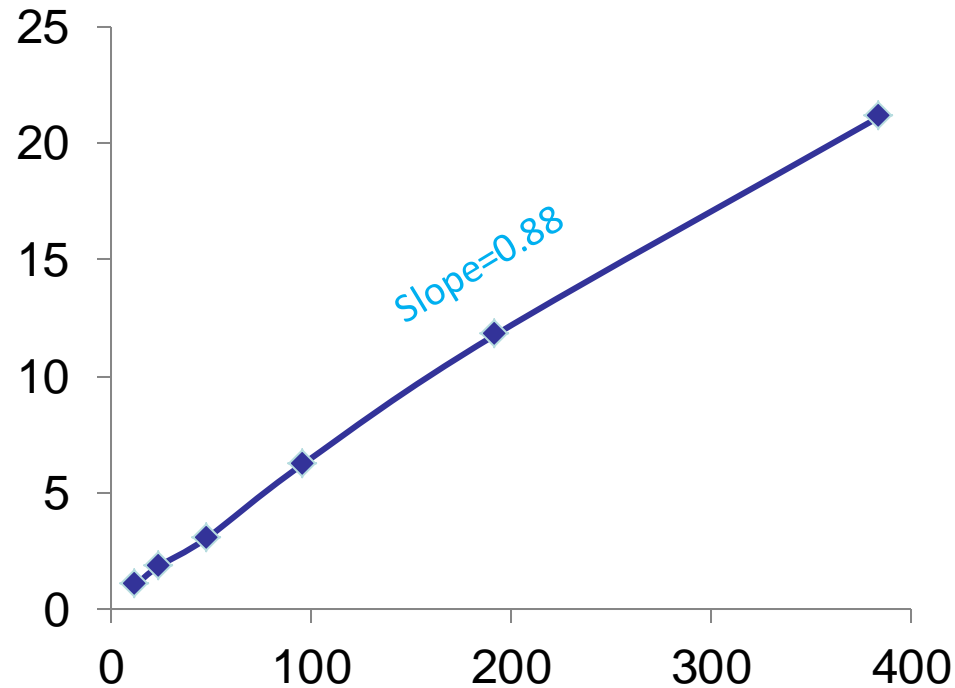

Note: 3 million elements, total time excluded MPP decomposition time

Application: Penetration – 50 million model

*ALE_STRUCTURED_MESH_REFINE

MSHID	NX	NY	NZ
1	5	5	5

50 million model
1075 x 300 x 150

LS-DYNA keyword deck by LS-PrePost
Time = 0

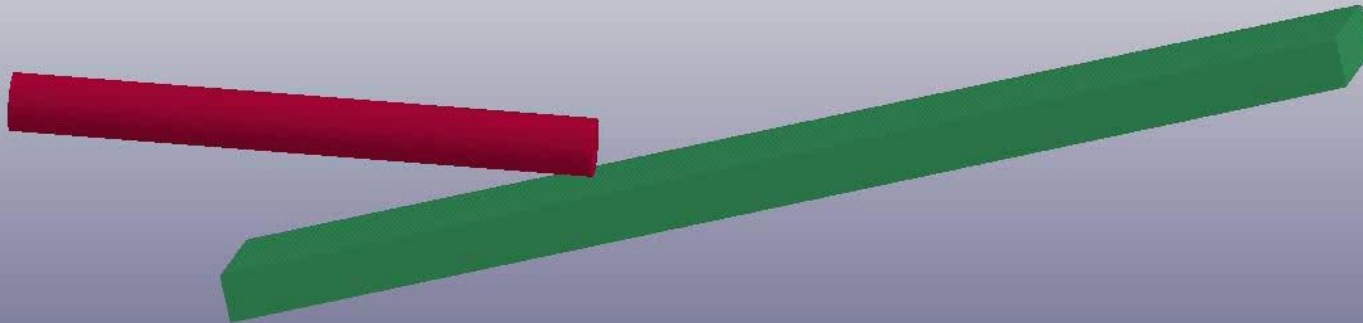

33.33 frame/sec

Application: Penetration – 50 million model

Memory Usage: PHASE 1 (Keyword) – 1028M; PHASE 2 (Decomposition) – 1406M

Maximum memory usage occurs in decomposition phase. We have a 2G memory limit for **single precision**. So this means by **single precision** executables S-ALE model size can be around 50 million to 70 million.

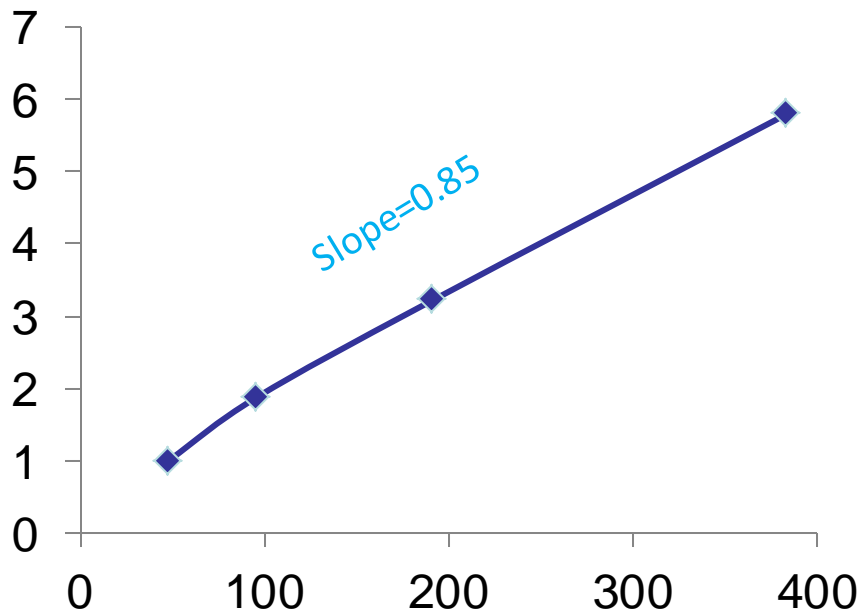

NCPU	Total Time	Advection
48	34966	17323
96	18624	9228
192	10837	5230
384	6032	2616

MPP scalability with 50m model

Application: Penetration – Memory Usage

Comparison of MPP Memory usage between ALE solver and S-ALE solver

With 48 CPU MPP single precision executable, we find the maximum number of elements ALE can handle. Then we run the same model using S-ALE to compare the memory usage.

*ALE_STRUCTURED_MESH_REFINE			
MSHID	NX	NY	NZ
1	4	4	2

12.5 million model
860 x 240 x 60

Memory usage	ALE	S-ALE
Keyword	812 M	267 M
Decomposition	2020 M	361 M

During decomposition phase, ALE uses ~5 times more memory than S-ALE. This makes the model size ALE can run with **single precision** is only 12.5 million.

Application: Explosion – Model Description

- Blast mine on plate; Model dimensions and material properties from “Validation of a Loading Model for Simulating Blast Mine Effects on Armoured Vehicles”, Williams et al, 7th International LS-DYNA Users Conference; DRDC (Defence R&D Canada)

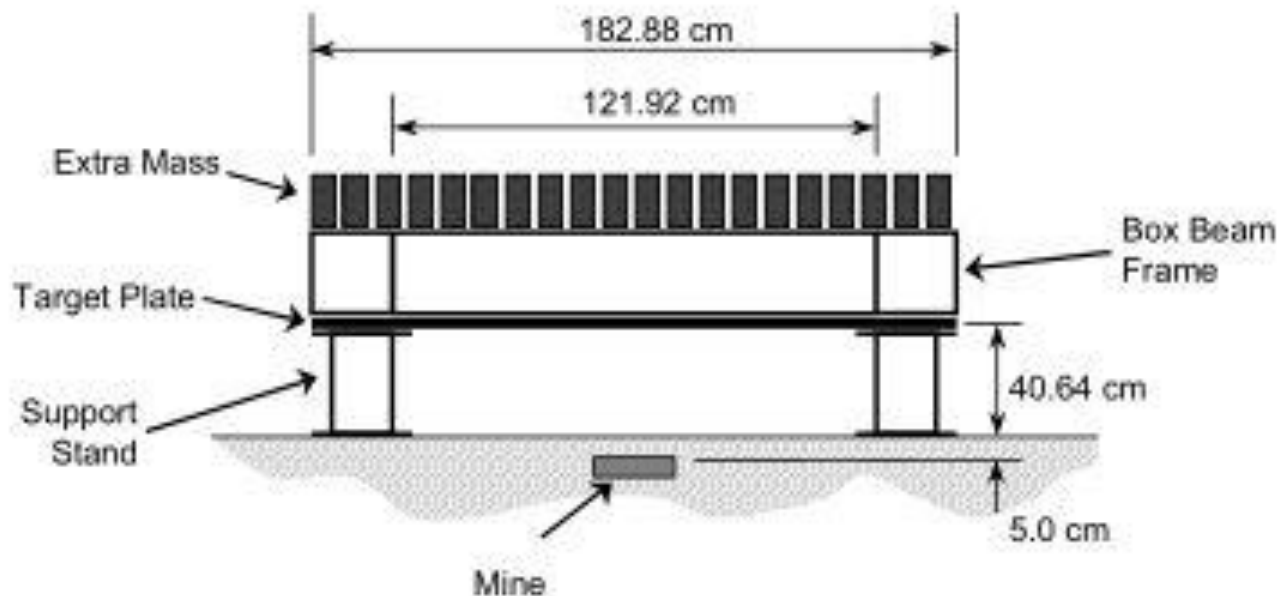

- S-ALE mesh spans from (-1.714, -1.714, -1.0) to (1.714, 1.714, 1.321) modeled by 1,339,200 (120x120x93) elements.

Application: Explosion – Simulation

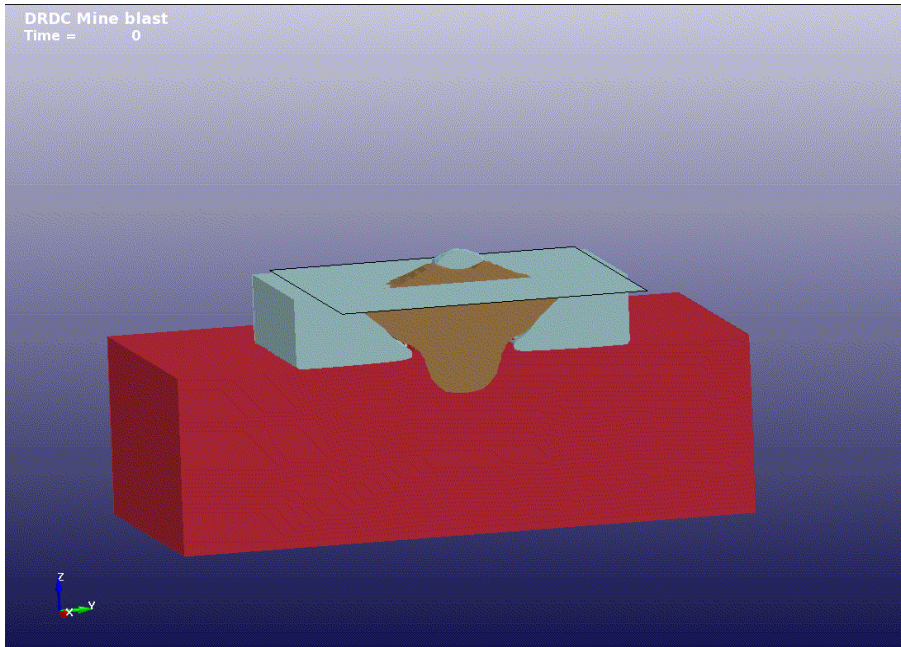

S-ALE: 1 hrs 47 mins
ALE: 4 hrs 28 mins

20ms simulation time
1.3 million S-ALE elements
MPP 48 cpus

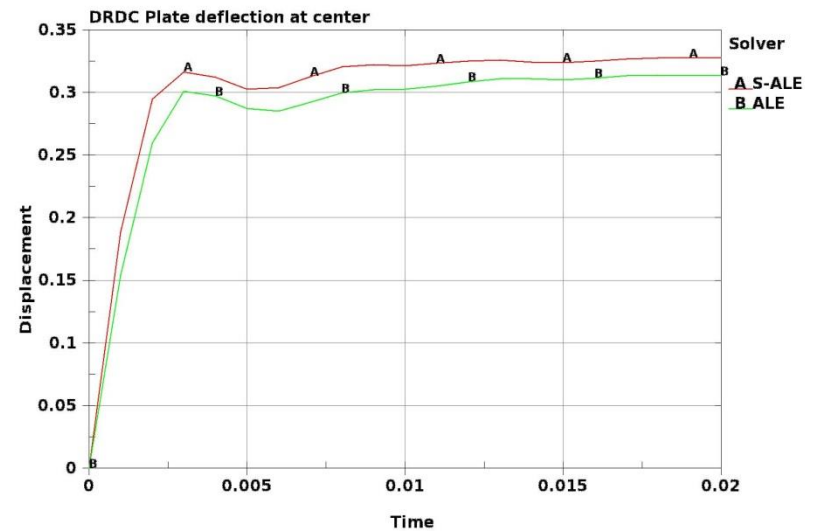

Application: Explosion – Model Setup 1

*ALE_STRUCTURED_MESH					
MSHID	PID	NBID	EBID		
1	999	5000001	5000001		
CPIDX	CPIDY	CPIDZ	NID0	LCSID	
1001	1001	1003			

MSHID: Mesh ID (for future use)

PID: Part ID assigned to the mesh
NO NEED to define *PART card

NBID: Starting Node ID

EBID: Starting Element ID

NID0: Origin Node ID

LCSID: Local Coordinate System ID

*ALE_STRUCTURED_MESH_CONTROL_POINTS			
1001			
	1		-1.714290
	121		1.714290

*ALE_STRUCTURED_MESH_CONTROL_POINTS			
1003			
	1		-1.000000
	32		-0.131200
	37		0.000000
	94		1.321190

Application: Explosion – Model Setup 2

*ALE_MULTI-MATERIAL_GROUP	
PID	PTYPE
3000	1
1000	1
2000	1
2001	1

1 to 1



*PART				
PID	SECID	MID	EOSID	HGID
3000	3000	3001	3001	3000
1000	1000	1001	1000	1000
2000	2000	2000	2000	2000
2001	2000	2000	2000	2000

PID	MATERIAL	AMMG
3000	HE	1
1000	SOIL	2
2000	AIR Below	3
2001	AIR Above	4

- *SECTION should always be 11. Same SECID OK.
- *HOURGLASS form and coefficient should always be 1 and 1.0e-6. Same HGID OK.
- PIDs not used elsewhere. Only to be put into *ALE_MULTI-MATERIAL_GROUP card.

Application: Explosion – Model Setup 3

*INITIAL_VOLUME_FRACTION_GEOMETRY							
SID	IDTYP	BAMMG					
999	1	4					
TYPE	FILLOPT	FAMMG				"5 = BOX"	
5	0	3					
X0	Y0	Z0	X1	Y1	Z1		
-1.0	-1.0	0.0	1.0	1.0	0.39404		
TYPE	FILLOPT	FAMMG				"3 = PLANE"	
3	0	2					
X0	Y0	Z0	NX	NY	NZ		
0.0	0.0	0.0	0.0	0.0	-1.0		
TYPE	FILLOPT	FAMMG				"4 = CYLINDER"	
4	0	1					
X0	Y0	Z0	NX	NY	NZ	R1	R2
0.0	0.0	-0.1312	0.0	0.0	-0.05080	0.12	0.12

1. All to "AIR Above";
2. Inside box to "AIR below";
3. Below plane to "SOIL";
4. Inside Cylinder to "HE"

Application: Explosion – Model Setup FSI

Couple plate to air below

*CONSTRAINED_LAGRANGE_IN_SOLID							
SLAVE	MASTER	SSTYP	MSTYP	NQUAD	CTYPE	DIREC	MCOUP
5000	999	1	1	2	4	2	-33
START	END	PFAC	FRIC	FRCMIN	NORM	NORMT	DAMP
		-54		0.3			
CQ	HMIN	HMAX	ILEAK	PLEAK			
			2	0.1			

Couple plate to HE and soil

*CONSTRAINED_LAGRANGE_IN_SOLID							
SLAVE	MASTER	SSTYP	MSTYP	NQUAD	CTYPE	DIREC	MCOUP
5000	999	1	1	2	4	2	-12
START	END	PFAC	FRIC	FRCMIN	NORM	NORMT	DAMP
		-55		0.3			
CQ	HMIN	HMAX	ILEAK	PLEAK			
			2	0.1			

Application: Explosion – Model Setup MISC

*CONTROL_ALE							
DCT	NADV	METHOD	AFAC	BFAC	CFAC	DFAC	EFAC
	1	1					
START	END	AAFAC	VFACT	PRIT	EBC	PREF	NSIDEBC
						101325.0	

Define NODESET SEGSET using *SET_”?”_GENERAL

*SET_SEGMENT_GENERAL							
SID							
1							
OPTION	MSHID	-X	X	-Y	Y	-Z	Z
SALEFAC	1	1	1				

*BOUNDARY_NON_REFLECTING		
SSID	AD	AS
1	0.0	0.0
2	0.0	0.0
3	0.0	0.0

Another newly added option in SET_?”_GENERAL
 SALECPT: It is to define a box with (xmin,ymin,zmin)
 to (xmax,ymax,zmax) in Control point nodal index.
 Nodes/Segments/Solids inside the box are included.

Application: Explosion – MPP Performance

NCPU	48	96	192	384
Total Time	6422	3580	2290	1440
S-ALE	4110	2120	1232	610
FSI	242	202	233	303

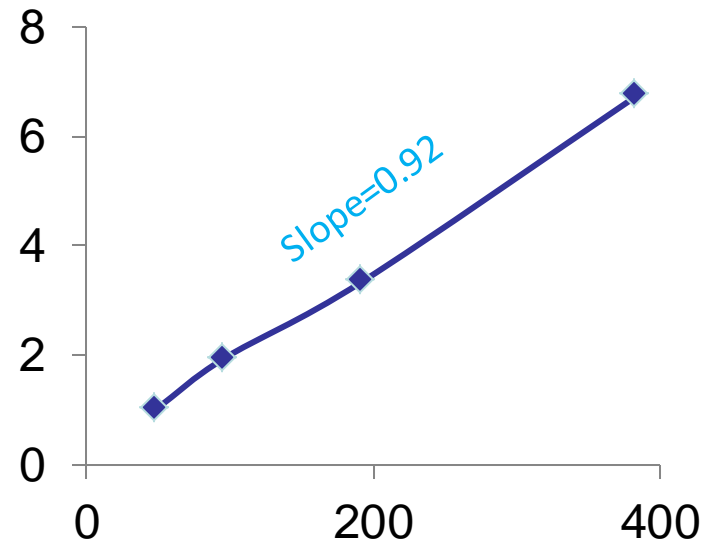
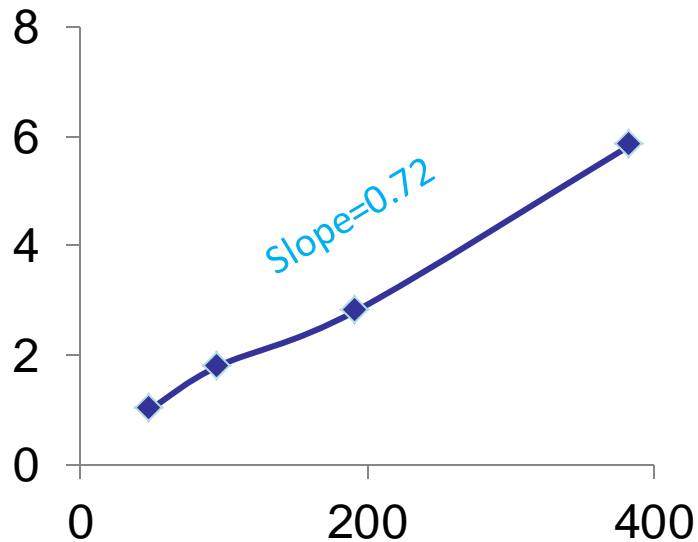

Application: Tank Sloshing – Model Description

- Fluids and tank system starts at rest (equilibrates for 1 ms). Tank then accelerates to 20 m/s, then decelerates to 0m/s to create sloshing.
- An impactor moving at -50 m/s strikes the tank.
- Unit system: kg-mm-ms-K; Total run time = 40 ms.

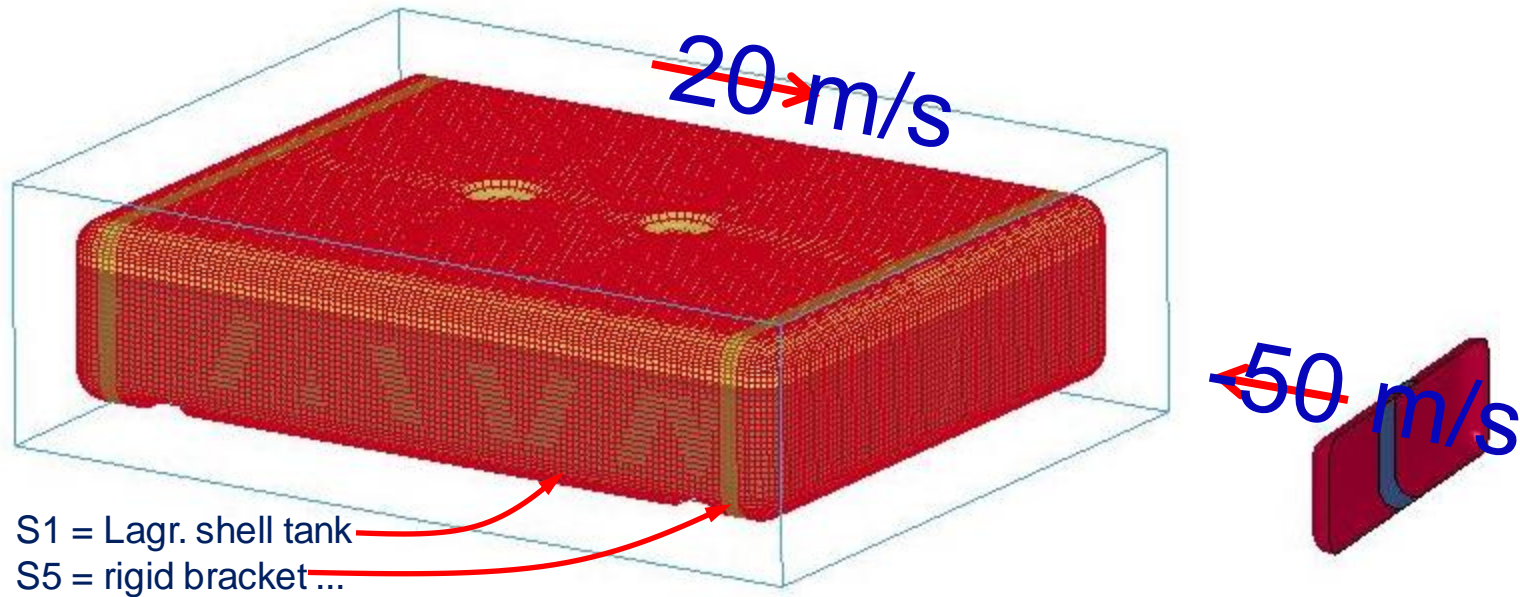

Application: Tank Sloshing – Simulation

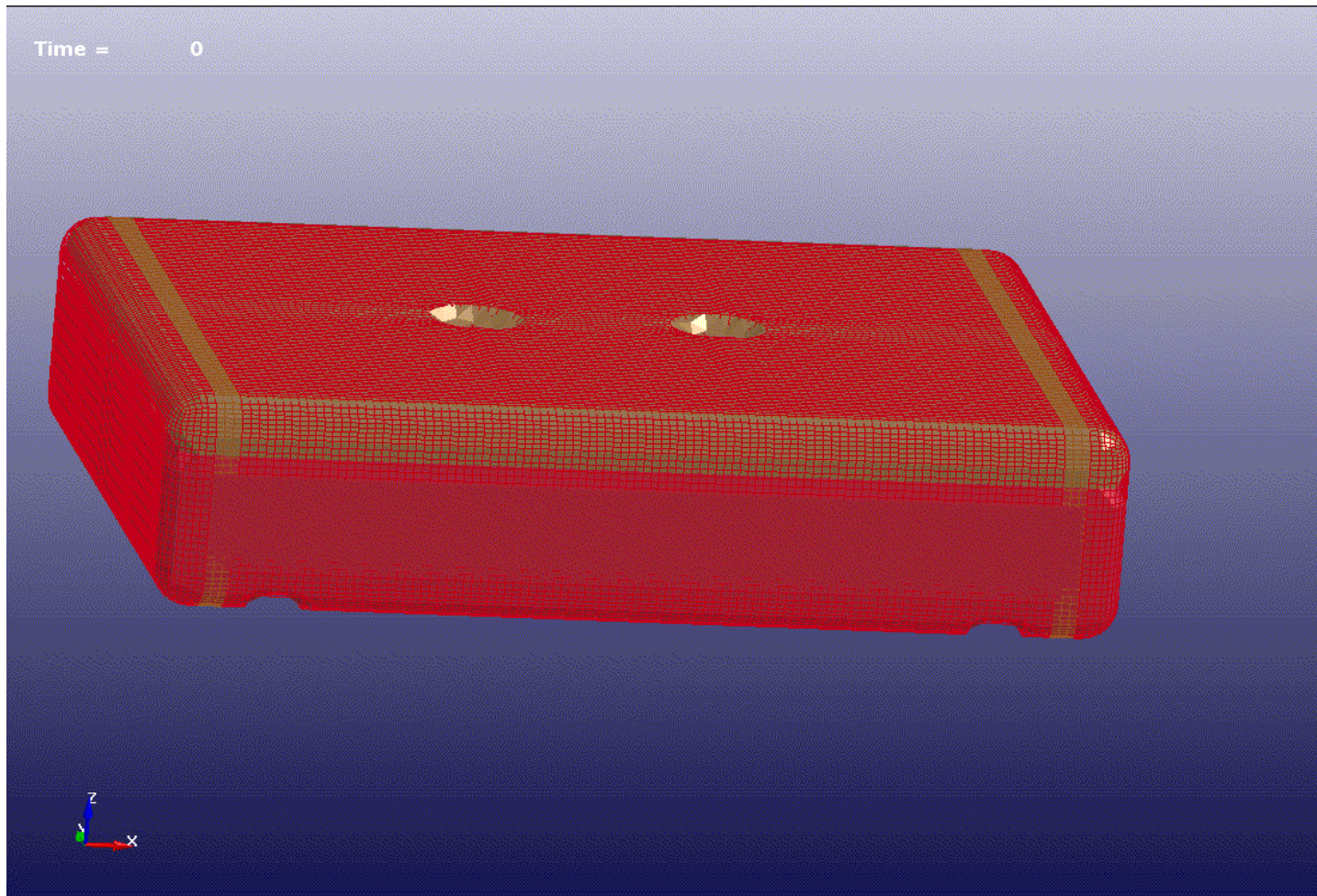

S-ALE: 1h41m; ALE: 2h30m (32% speedup)

MPP dev.105342 single precision 12 CPU

Application: Tank Sloshing – Model Setup 1

*ALE_STRUCTURED_MESH					
MSHID	PID	NBID	EBID		
1	202	2000001	2000001		
CPIDX	CPIDY	CPIDZ	NID0	LCSID	
1001	1002	1003	34081	234	

MSHID: Mesh ID (for future use)

PID: Part ID assigned to the mesh
NO NEED to define *PART card

NBID: Starting Node ID

EBID: Starting Element ID

NID0: Origin Node ID

LCSID: Local Coordinate System ID

*ALE_STRUCTURED_MESH_CONTROL_POINTS			
1001			363.31729
	1		-500.
	75		525.

*ALE_STRUCTURED_MESH_CONTROL_POINTS			
1002			-107.0625
	1		-375.
	57		375.

*ALE_STRUCTURED_MESH_CONTROL_POINTS			
1003			
	1		-90.
	23		260.

Application: Tank Sloshing – Model Setup 1

*ALE_STRUCTURED_MESH					
MSHID	PID	NBID	EBID		
1	202	2000001	2000001		
CPIDX	CPIDY	CPIDZ	NID0	LCSID	
1001	1002	1003	34081	234	

*DEFINE_COORDINATE_NODES					
234	34081	33961	25032		1

Node 34081, 33961, 25032 are three nodes on the Lagrange rigid body part

*NODE				
34081	-3.6331729e+2	-1.070625e+2		0.0000000
33961	-3.432692e+2	-1.070625e+2		0.0000000
25032	-3.6331729e+2	2.0965269e+2		0.0000000

Application: Tank Sloshing – Model Setup 2

*ALE_MULTI-MATERIAL_GROUP	
PID	PTYPE
2	1
3	1
4	1

1 to 1



*PART				
PID	SECID	MID	EOSID	HGID
2	2	2	2	2
3	3	3	3	3
4	4	4	4	4

PID	MATERIAL	AMMG
2	AIR outside	1
3	Vapor inside	2
4	Fuel inside	3

- *SECTION should always be 11. Same SECID OK.
- *HOURLASS form and coefficient should always be 1 and 1.0e-6. Same HGID OK.
- PIDs not used elsewhere. Only to be put into *ALE_MULTI-MATERIAL_GROUP card.

Application: Tank Sloshing – Model Setup 3

*INITIAL_VOLUME_FRACTION_GEOMETRY							
SID	IDTYP	BAMMG					
202	1	3					
TYPE	FILLOPT	FAMMG					“3 = PLANE”
3	0	2					
X0	Y0	Z0	X1	Y1	Z1		
-6.5	-300.0	132.0	0.0	0.0	0.0		
TYPE	FILLOPT	FAMMG					“1 = PART/PSET”
1	1	1					
SETID	SETTYP	NORMD					
15	0						

1. All to “Fuel”;
2. Above the plan to “Vapor”;
3. Outside the part 1+5 to “Air”

Application: Tank Sloshing – Model Setup FSI

Couple tank to air outside

*CONSTRAINED_LAGRANGE_IN_SOLID							
SLAVE	MASTER	SSTYP	MSTYP	NQUAD	CTYPE	DIREC	MCOUP
15	202	0	1	2	4	2	-11
START	END	PFAC	FRIC	FRCMIN	NORM	NORMT	DAMP
		-3			1		
CQ	HMIN	HMAX	ILEAK	PLEAK			
			2	0.1			

Couple tank to vapor inside

*CONSTRAINED_LAGRANGE_IN_SOLID							
SLAVE	MASTER	SSTYP	MSTYP	NQUAD	CTYPE	DIREC	MCOUP
15	202	0	1	2	4	2	-22
START	END	PFAC	FRIC	FRCMIN	NORM	NORMT	DAMP
		-3					
CQ	HMIN	HMAX	ILEAK	PLEAK			
			2	0.1			

Application: Tank Sloshing – Model Setup FSI

Couple tank to Fuel inside

*CONSTRAINED_LAGRANGE_IN_SOLID							
SLAVE	MASTER	SSTYP	MSTYP	NQUAD	CTYPE	DIREC	MCOUP
15	202	0	1	2	4	2	-33
START	END	PFAC	FRIC	FRCMIN	NORM	NORMT	DAMP
		-4					
CQ	HMIN	HMAX	ILEAK	PLEAK			
			2	0.1			

Different combinations of coupling cards can be defined.

- 1 card only
 - tank to inside vapor + fuel
- 2 cards
 - tank to inside vapor + fuel
 - tank to outside air
- 3 cards
 - tank to inside vapor
 - tank to inside fuel
 - tank to outside air

Application: Tank Sloshing – Model Setup MISC

*CONTROL_ALE							
DCT	NADV	METHOD	AFAC	BFAC	CFAC	DFAC	EFAC
	1	1					
START	END	AAFAC	VFACT	PRIT	EBC	PREF	NSIDEBC
						1.01325e-4	

Include hydrostatic pressure in the calculation

*INITIAL_HYDROSTATIC_ALE				
SID	STYPE	VECID	GRAV	PBASE
202	1	1	9.81e-3	1.01325e-4
NID	MMGBelow			
294095	1			
900001	2			
900002	3			

*LOAD_BODY_Z	
LCID	SF
6	0.00981

Application: Explosion II – Model Description

- Blast mine on two boxes; All box edge nodes are fixed. To study HE/Soil motion at an contact angle.
- S-ALE mesh spans from $(-65.0, -65.0, 0.0)$ to $(65.0, 65.0, 80.0)$ modeled by 1,352,000 $(130 \times 130 \times 80)$ elements; Box dimension $25 \times 20 \times 50$ placed at an angle of 30 degree to the ground.
- Unit system g-cm-mcrs

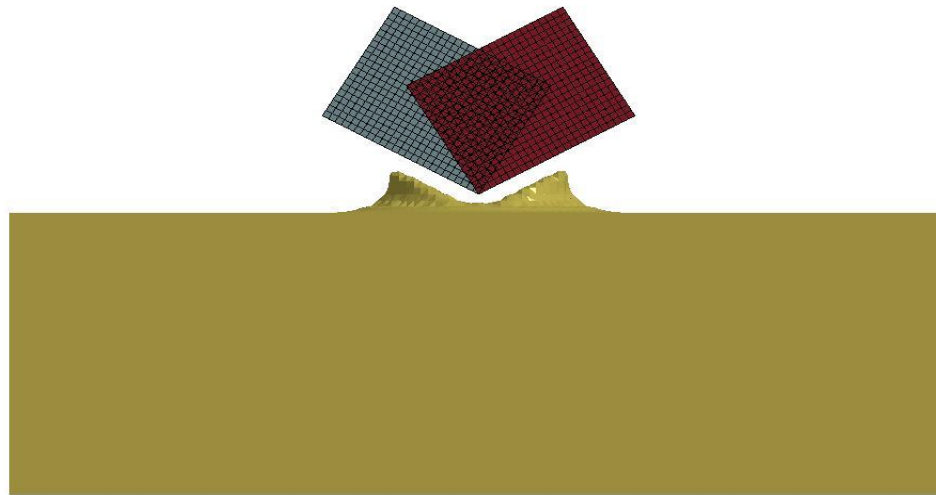

Application: Explosion II – Model Setup 1

*ALE_STRUCTURED_MESH					
MSHID	PID	NBID	EBID		
1	101	100001	100001		
CPIDX	CPIDY	CPIDZ	NID0	LCSID	
1001	1001	1003			

MSHID: Mesh ID (for future use)

PID: Part ID assigned to the mesh
NO NEED to define *PART card

NBID: Starting Node ID

EBID: Starting Element ID

NID0: Origin Node ID

LCSID: Local Coordinate System ID

*ALE_STRUCTURED_MESH_CONTROL_POINTS			
1001			
	1		-65.
	131		65.

*ALE_STRUCTURED_MESH_CONTROL_POINTS			
1003			
	1		0.
	81		80.

Application: Explosion II – Model Setup 1

*SET_SEGMENT_GENERAL							
SID							
1							
OPTION	MSHID	XMIN	XMAX	YMIN	YMAX	ZMIN	ZMAX
SALEFAC	1	1	1				

*SET_SEGMENT_GENERAL							
SID							
2							
OPTION	MSHID	XMIN	XMAX	YMIN	YMAX	ZMIN	ZMAX
SALEFAC	1			1	1		

SALEFAC option in *SET_SEGMENT/NODE/SOLID_GENERAL will include all segments/nodes/solids at S-ALE mesh face.

XMIN/XMAX, YMIN/YMAX, ZMIN/ZMAX: 6 faces at LOCAL coordinate system.

Application: Explosion II – Model Setup 2

*ALE_MULTI-MATERIAL_GROUP	
PID	PTYPE
2	1
3	1
4	1

1 to 1



*PART				
PID	SECID	MID	EOSID	HGID
2	2	2	2	2
3	3	3	3	2
4	4	4	4	2

PID	MATERIAL	AMMG
2	HE	1
3	Soil	2
4	Air	3

- *SECTION should always be 11. Same SECID OK.
- *HOURGLASS form and coefficient should always be 1 and 1.0e-6. Same HGID OK.
- PIDs not used elsewhere. Only to be put into *ALE_MULTI-MATERIAL_GROUP card.

Application: Explosion II – Model Setup 3

*INITIAL_VOLUME_FRACTION_GEOMETRY							
SID	IDTYP	BAMMG					
101	1	2					
TYPE	FILLOPT	FAMMG				"4 = Cone"	
4	0	1					
X0	Y0	Z0	X1	Y1	Z1	R1	R2
0.0	0.0	36.0	0.0	0.0	40.0	5.5	5.5
TYPE	FILLOPT	FAMMG				"1 = PART/PSET"	
3	0	3					
X0	Y0	Z0	XCOS	YCOS	ZCOS		
-3.5	-3.5	45.0	0	0	1		

1. All to "Soil";
2. Inside the cylinder h=4cm, r=5.5cm and buried 5cm under soil to "HE";
3. Above the plane (z=45cm) to "Air"

Application: Explosion II – Model Setup FSI & MISC

Couple boxes to HE and Soil

*CONSTRAINED_LAGRANGE_IN_SOLID							
SLAVE	MASTER	SSTYP	MSTYP	NQUAD	CTYPE	DIREC	MCOUP
12	101	0	1	2	4	2	-12
START	END	PFAC	FRIC	FRCMIN	NORM	NORMT	DAMP
		-5					
CQ	HMIN	HMAX	ILEAK	PLEAK			
			2	0.1			
IBOXID	IPENCK	INTFOR	IALESOF	LAGMUL	PFACMM	THKF	
						1.0	

Transmitting boundary

*BOUNDARY_NON_REFLECTING		
SEGID	AD	AS
1	0.0	0.0
2	0.0	0.0
3	0.0	0.0

Explosion center

*INITIAL_DETONATION				
PID	X	Y	Z	LT
101	0.0	0.0	36.0	0.0

Application: Explosion II – Result

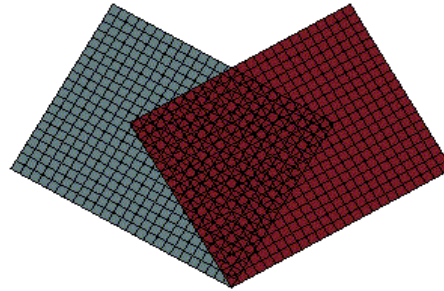

S-ALE :18min57s 2043 cycles; ALE: 24min47s 2382 cycles .
Per cycle time: S-ALE 384 versus ALE 428 (nano-second); 10% speedup
12 CPU MPPDYNA dev.105342 single precision

Application: Floating Ship – Model Description

- Water and air domains are initialized with hydrostatic pressure.
- A “ship” (closed shell container) containing a liquid and a gas floats via buoyancy force on the surface of the water.
- Then artificial wave is generated (LHS) and the wave interacts with the external surface of the ship while the internal fluids interact with the internal surface of the ship.
- Unit Kg-m-s

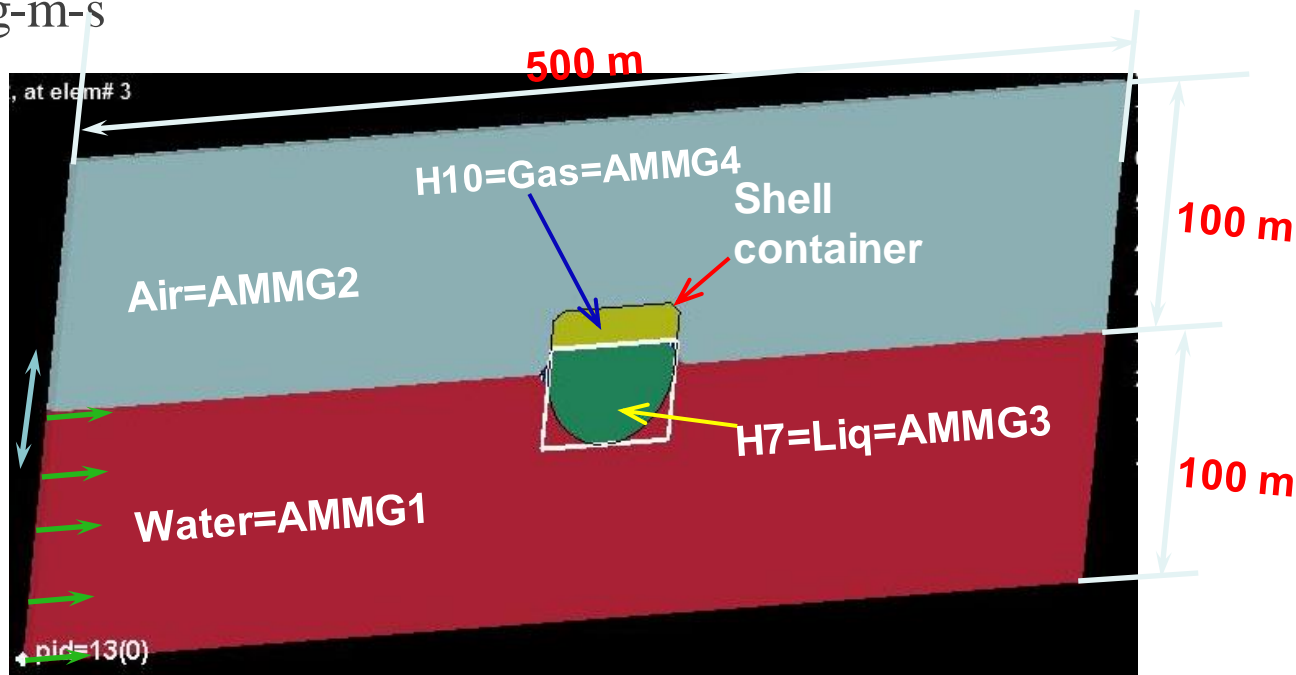

Application: Floating Ship – Model Setup 1

*ALE_STRUCTURED_MESH					
MSHID	PID	NBID	EBID		
1	11	300001	300001		
CPIDX	CPIDY	CPIDZ	NID0	LCSID	
1001	1002	1003			

MSHID: Mesh ID (for future use)

PID: Part ID assigned to the mesh
NO NEED to define *PART card

NBID: Starting Node ID

EBID: Starting Element ID

NID0: Origin Node ID

LCSID: Local Coordinate System ID

*ALE_STRUCTURED_MESH_CONTROL_POINTS		
1001		
1		0.
101		500.

*ALE_STRUCTURED_MESH_CONTROL_POINTS		
1002		
1		0.
41		200.

*ALE_STRUCTURED_MESH_CONTROL_POINTS		
1003		
1		0.
2		5.

Application: Floating Ship – Model Setup 2

*ALE_MULTI-MATERIAL_GROUP	
PID	PTYPE
1	1
3	1
7	1
10	1

1 to 1



*PART				
PID	SECID	MID	EOSID	HGID
1	1	1	1	1
3	1	3	3	1
7	1	7	7	1
10	1	3	3	1

PID	MATERIAL	AMMG
1	Water	1
3	Air	2
7	Fluid inside	3
10	Air inside	4

- *SECTION should always be 11. Same SECID OK.
- *HOURGLASS form and coefficient should always be 1 and 1.0e-6. Same HGID OK.
- PIDs not used elsewhere. Only to be put into *ALE_MULTI-MATERIAL_GROUP card.

Application: Floating Ship – Model Setup 3

*INITIAL_VOLUME_FRACTION_GEOMETRY							
SID	IDTYP	BAMMG					
11	1	1					
TYPE	FILLOPT	FAMMG					“3 = Plane”
3	0	2					
X0	Y0	Z0	XCOS	YCOS	ZCOS		
10.0	100.0	0.0	0.0	0.0	1.0		
TYPE	FILLOPT	FAMMG					“1 = PART/PSET”
1	0	3					
SETID	SETTYP	NORMD	XOFF				
5	1						
TYPE	FILLOPT	FAMMG					“1 = PART/PSET”
1	0	4					
SETID	SETTYP	NORMD	XOFF				
6	1						

1. All to “water”; 2. Above the plane to “air”; 3. Inside PART 5 to “fluid inside”; 4. Inside PART 6 to “air inside”

Application: Floating Ship – Hydrostatic Pressure 1

*ALE_AMBIENT_HYDROSTATIC

SID	STYPE	VECID	GRAV	PBASE
101	2	1	9.80665	101325.
NID	MMGB			
20002	2			
20001	1			

*ALE_AMBIENT_HYDROSTATIC

SID	STYPE	VECID	GRAV	PBASE
102	2	1	9.80665	101325.
NID	MMGB			
20002	2			
20000	1			

*BOUNDARY_PRESCRIBED_MOTION_NODE

SID	DOF	VAD	LCID
20001	2	2	6

*DEFINE_CURVE

LCID	SIDR	SFA	SFO
6			35.
TIME		Y=SIN(T)	
0.0			0.0
...			...
4.5			1.0
...			...
50.0			0.0

Apply hydrostatic pressure on a collection of solid elements at the mesh boundary. A moving node will create waves.

Application: Floating Ship – Hydrostatic Pressure 2

*SET_SOLID_GENERAL

SID					Two layers of elements at -X face		
101							
OPTION	MSHID	XMIN	XMAX	YMIN	YMAX	ZMIN	ZMAX
SALECPT	1	1	3	1	41	1	2

*SET_SOLID_GENERAL

SID					Two layers of elements at X face		
102							
OPTION	MSHID	XMIN	XMAX	YMIN	YMAX	ZMIN	ZMAX
SALECPT	1	99	101	1	41	1	2

*BOUNDARY_SPC_NODE

SID	CID	DOFX	DOFY	DOFZ
20000	0	1	1	1
20002	0	1	1	1

*LOAD_BODY_Y

LCID	SF
1	9.80665

Application: Floating Ship – Hydrostatic Pressure 3

*INITIAL_HYDROSTATIC_ALE

SID	STYPE	VECID	GRAV	PBASE
1	2	1	9.80665	101325.
NID	MMGB			
20002	2			
30500	4			
20164	3			
20001	1			

To apply initial hydrostatic pressure on all the fluids inside the S-ALE mesh

*SET_SOLID_GENERAL

SID					Two layers of elements at X face		
1							
OPTION	MSHID	XMIN	XMAX	YMIN	YMAX	ZMIN	ZMAX
SALECPT	1	1	101	1	41	1	2

Application: Floating Ship – Boundary Condition 1

All ALE nodes constrained at Z direction

*BOUNDARY_SPC_SET							
NSID	CID	DOFX	DOFY	DOFZ	DOFRX	DOFRY	DOFRZ
1				1			

-Y surface nodes constrained at all directions

*BOUNDARY_SPC_SET							
NSID	CID	DOFX	DOFY	DOFZ	DOFRX	DOFRY	DOFRZ
2		1	1	1			

3 layers of nodes at -X face with a prescribed X velocity

*BOUNDARY_PRESCRIBED_MOTION_SET							
NSID	DOF	VAD	LCID				
4	1	0	3				

Application: Floating Ship – Boundary Condition 2

*SET_NODE_GENERAL

SID					All Nodes of S-ALE mesh		
1							
OPTION	MSHID	XMIN	XMAX	YMIN	YMAX	ZMIN	ZMAX
SALECPT	1	1	101	1	41	1	2

*SET_NODE_GENERAL

SID					-Y face Nodes		
2							
OPTION	MSHID	XMIN	XMAX	YMIN	YMAX	ZMIN	ZMAX
SALEFAC	1			1			

*SET_NODE_GENERAL

SID					3 layers of -X face Nodes		
4							
OPTION	MSHID	XMIN	XMAX	YMIN	YMAX	ZMIN	ZMAX
SALECPT	1	1	3	1	41	1	2

Application: Floating Ship – Result

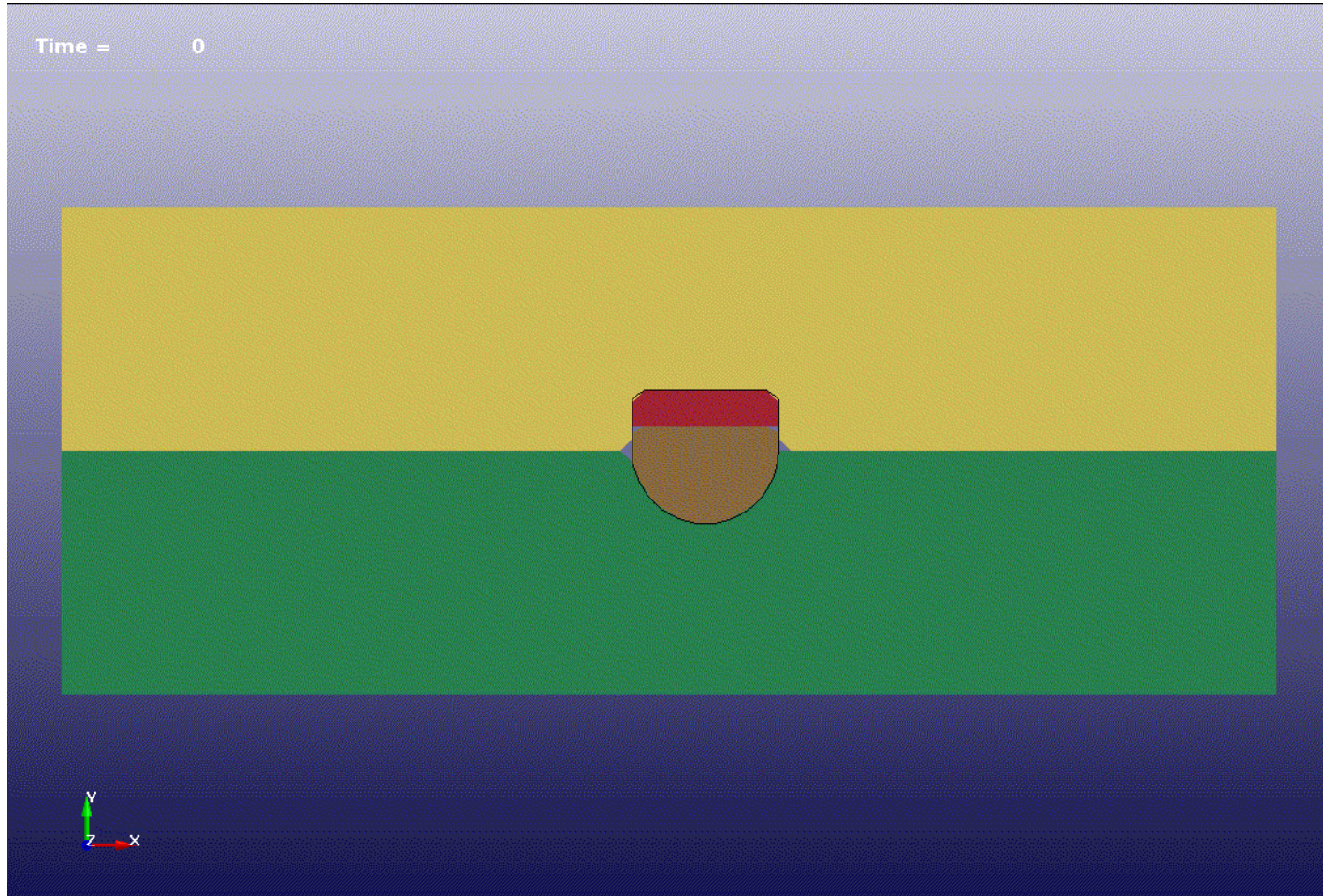

S-ALE : 699s; ALE: 806s 1 CPU LSDYNA dev.106021 single precision

ALE – The Method

ALE - Element Formulations

- 1) ALE formulation (single material domain).
- 2) ALE formulation with multi-materials in an element. (Translating/ Rotating/ Expanding mesh systems.)

ELFORM: (*SECTION_SOLOD)

- *5 = 1-point ALE element (single material domain).*
- *6 = 1-point Eulerian element (single material domain).*
- *7 = 1-point Eulerian Ambient element (single material domain).*
- *12 = 1-point ALE single-material-and-void (two-material domain).*
- **11 = 1-point ALE multi-material element ← most important**

ALE – Single Material Formulation

ALE SINGLE MATERIAL (ELFORM=5)

- One material – one mesh. Lagrangian-like! The overall mesh follows the overall material domain.
- Mesh smoothing – Moving the nodes to alleviate mesh distortion.

(ALE :Material(s) can flow through a mesh which itself can move)

PURE Lagrangian

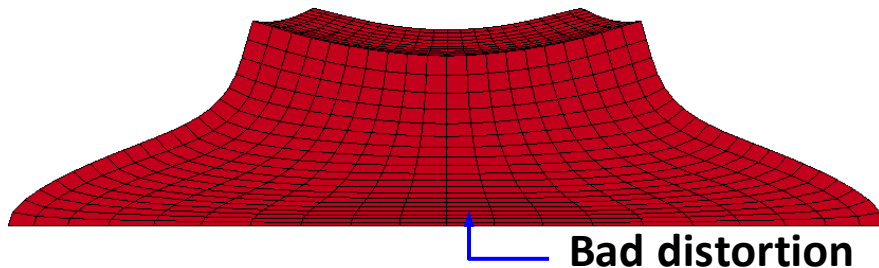

ALE Single Material

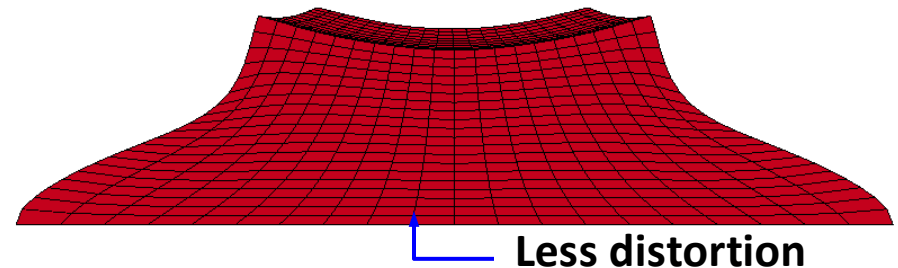

Eulerian Formulation

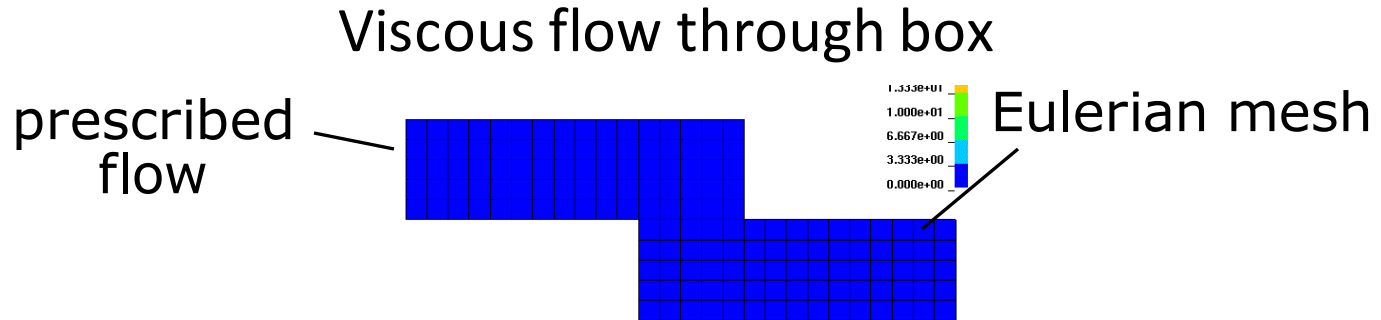

a)

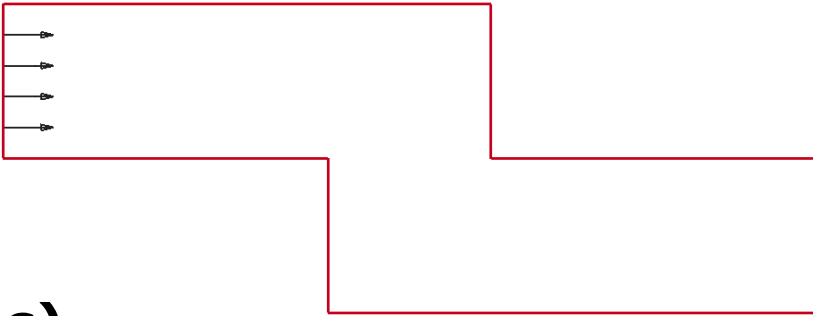

b)

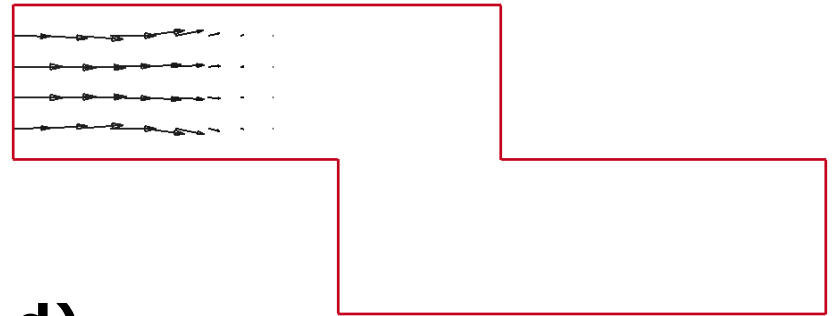

c)

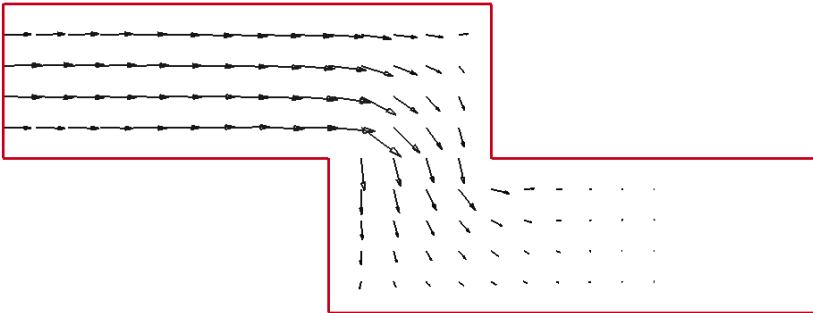

d)

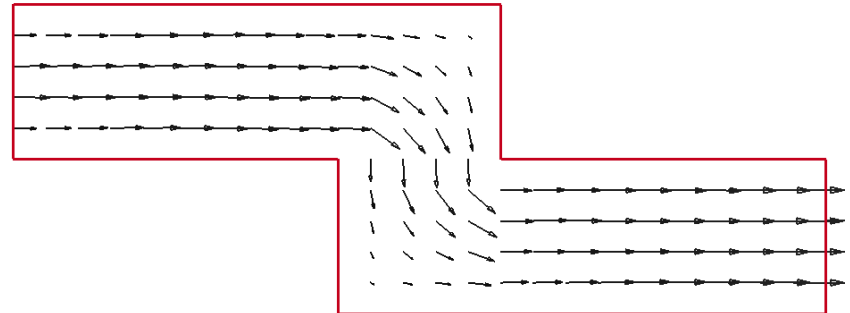

ALE - Mesh

Consider a 2D example, a solid piece of material is moved and then deformed as shown below. Three formulations may be used: (1) Lagrangian, (2) Eulerian, (3) ALE (Arbitrary-Lagrangian-Eulerian).

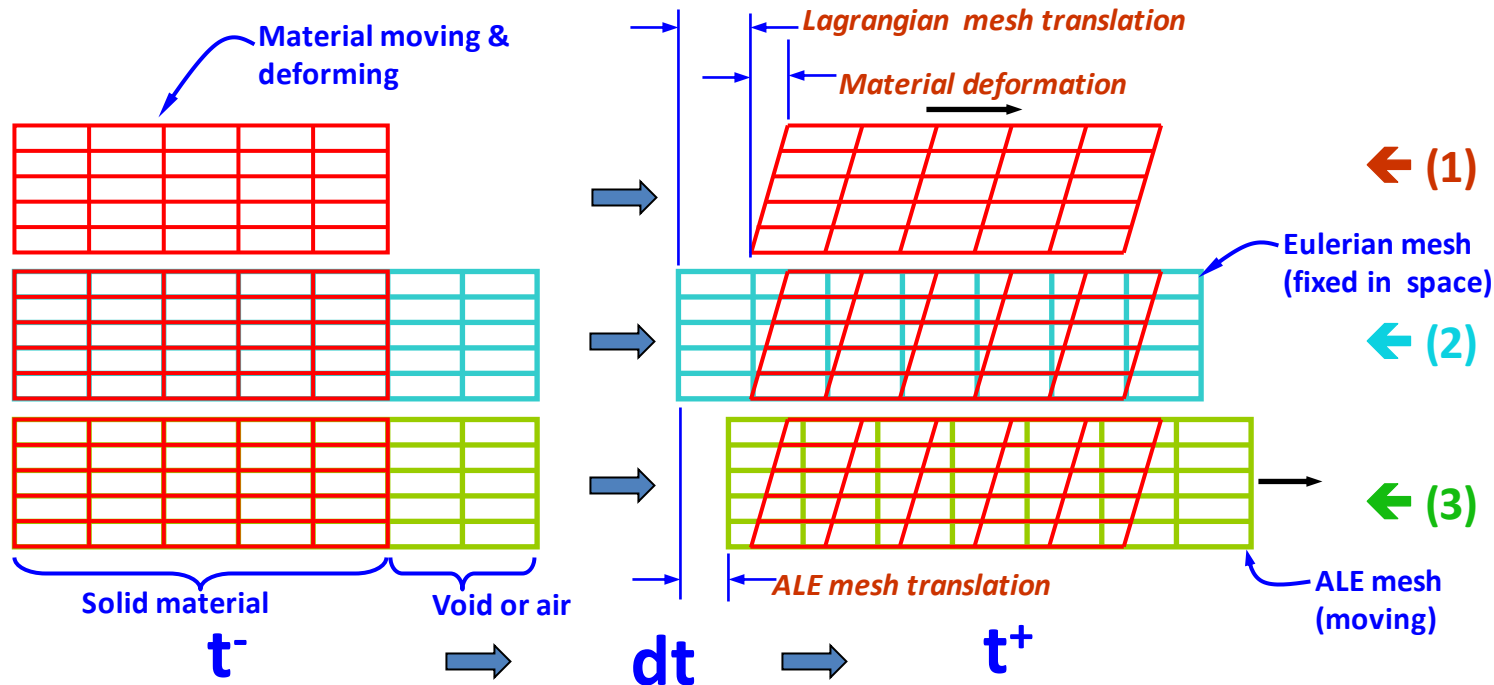

Multi-material Formulation

The material flows through a fixed mesh. Each element is allowed to contain a mixture of different materials.

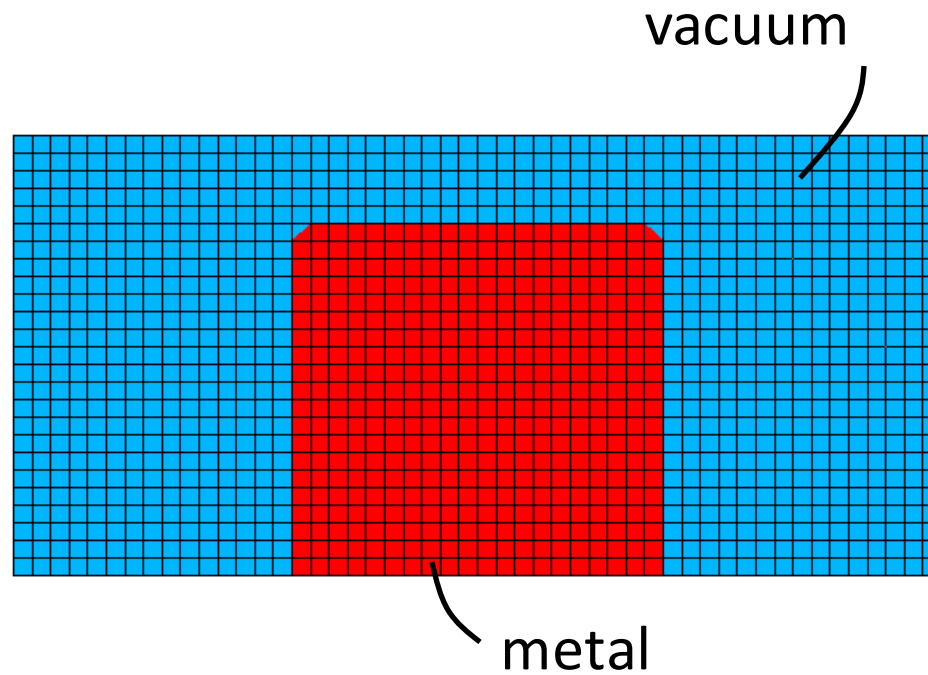

Multi-material ALE Formulation

By introducing mesh motion in the multi-material formulation, the model can be made smaller and the numerical errors can be kept on a lower level.

the mesh is allowed to move

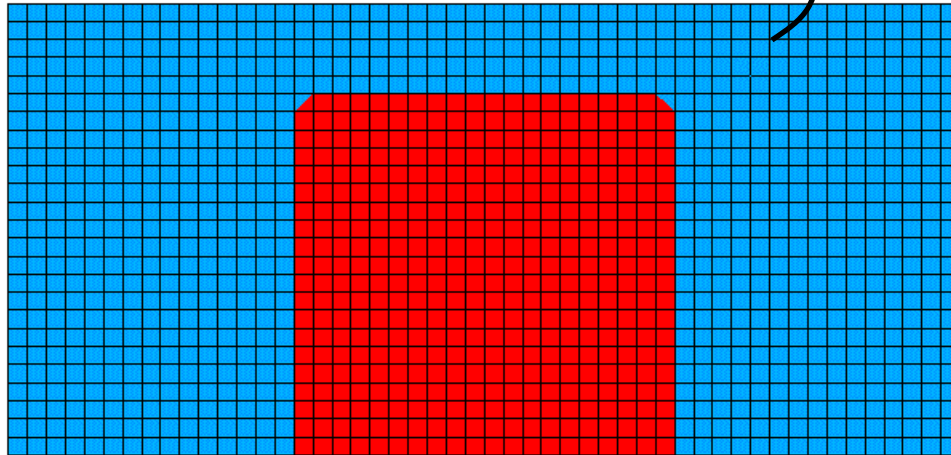

Advection -- Time Integration Loop

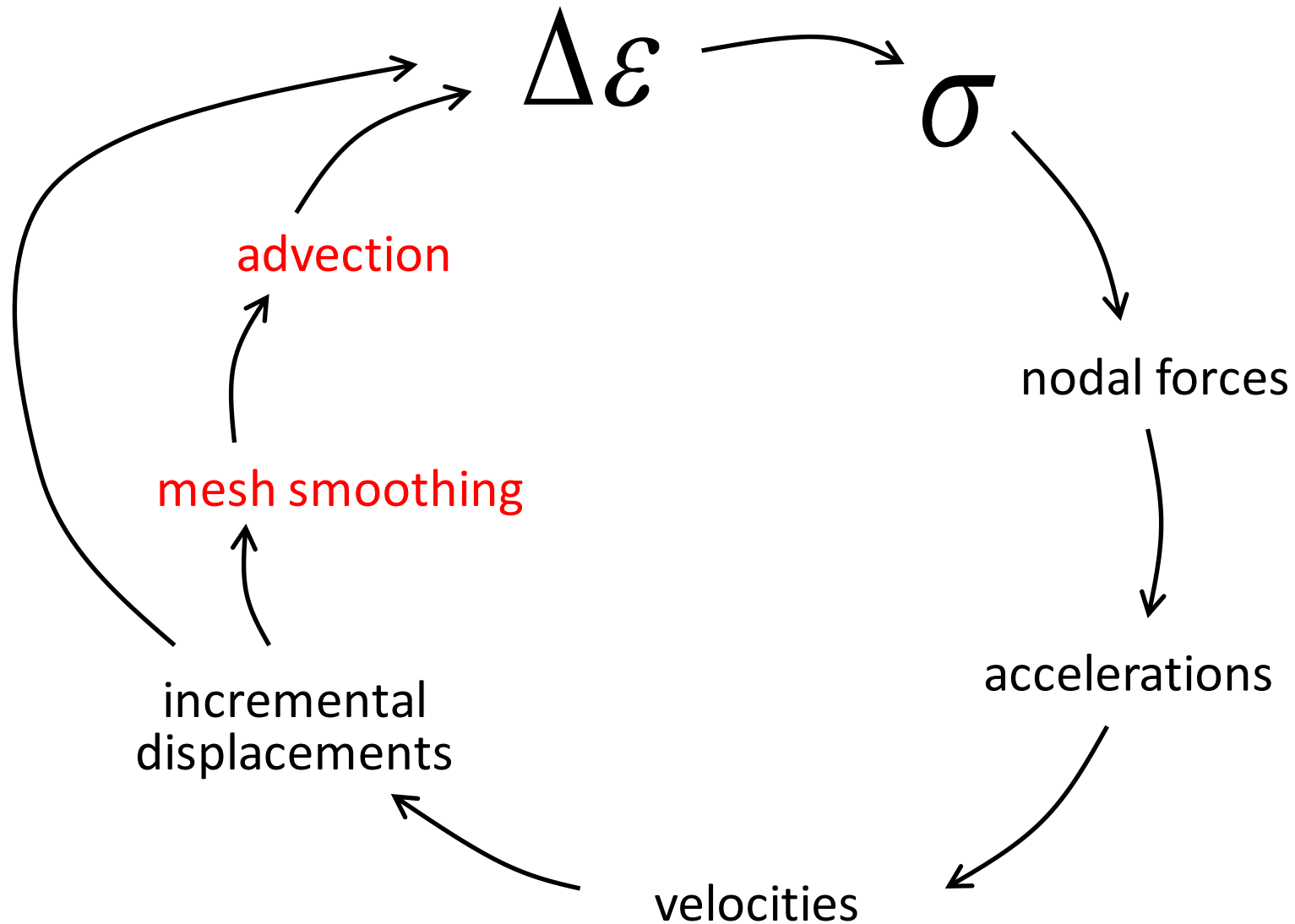

Advection

- After repositioning the nodes, all history variables and velocities need to be mapped from the old configuration onto the new one.
- This is referred to as the **advection step**.
- There are two different advection algorithms in LS-DYNA, one is spatially 1st order accurate and one is 2nd order accurate.
- The 1st order method is the **Donor Cell** scheme and the 2nd order one is the **van Leer** scheme.
- Both methods use the half index shift (HIS) scheme for advection of node centered variables (velocities and temperatures).

Advection – Donor Cell

elements before
node repositioning

element centered
history variable

$$\phi_0^{new} = \frac{\phi_0 V_0 + \phi_2 V_2 + \phi_4 V_4}{V_0 + V_2 + V_4}$$

center element after
node repositioning

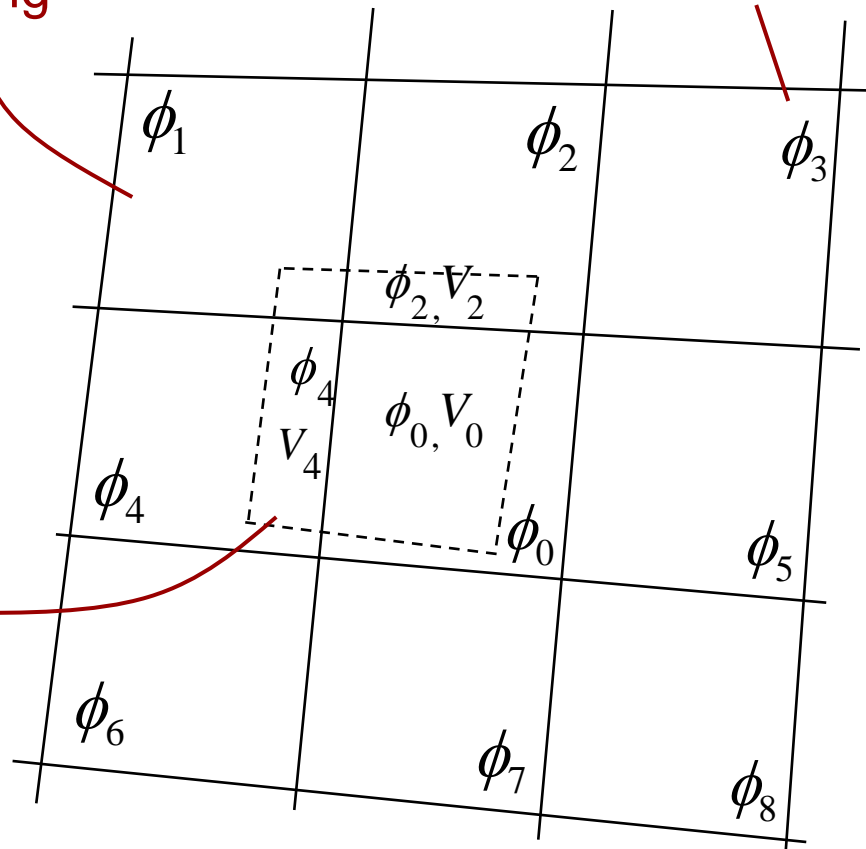

Advection – Donor Cell

A one-dimensional Donor cell example will help us better understanding the van Leer scheme.

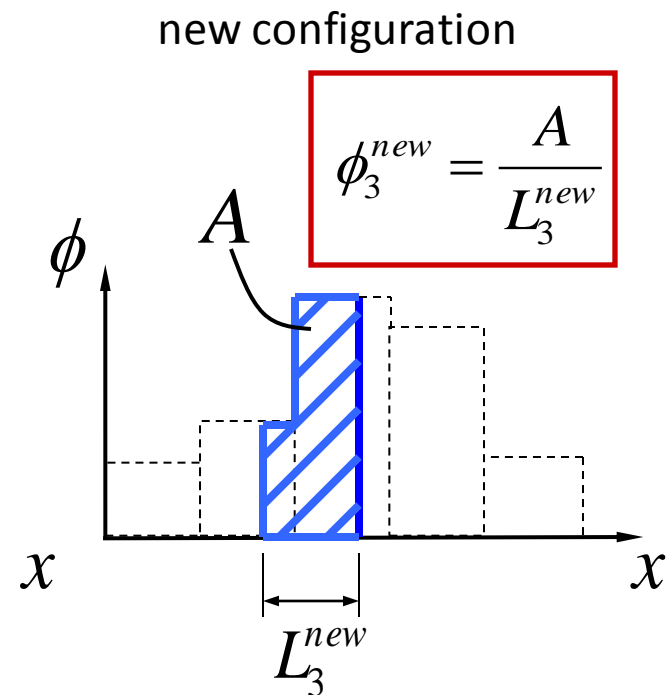
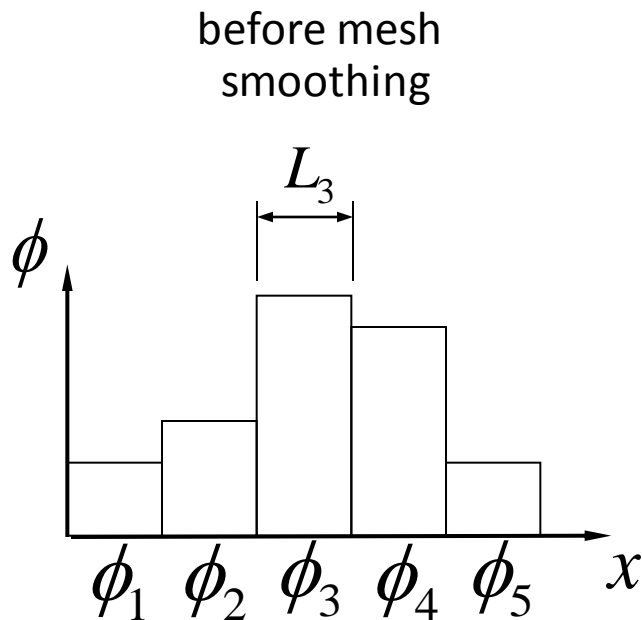

Advection – Van Leer

The van Leer scheme is monotonic, conservative, 2nd order accurate, but much slower than the Donor cell method. It is based on the assumption of a mesh with rectangular elements. Distorted elements introduce some 2nd order errors and the scheme actually becomes 1st order accurate.

The basic idea is to reconstruct an assumed a linear variation of the history variable fields. These assumed fields are mapped from the old mesh onto the new configuration.

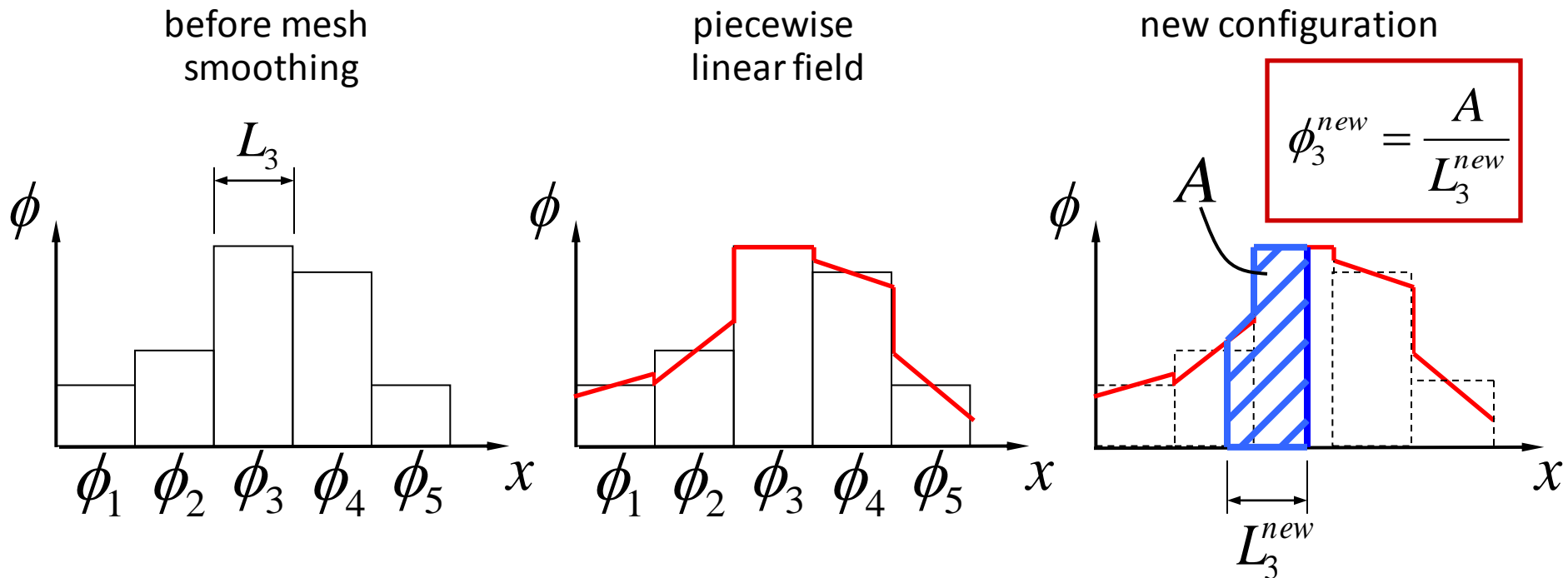

Advection – Half Index Shift

Node centered variables need a special treatment in the advection. The complexity of the applied scheme is motivated by the wish to have a conservative method. For example, it is desirable to preserve the total momentum of the system, when advecting velocities.

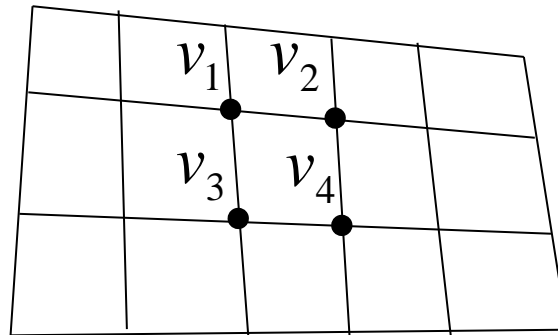

1. Move the velocities to the integration points (4 different positions in 2D and 8 in 3D).
2. Advect using the standard Donor cell or van Leer scheme.
3. Move velocities back to the nodes.

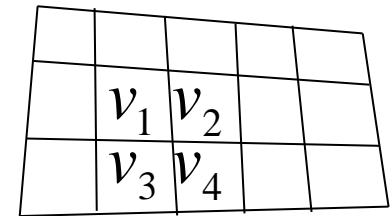
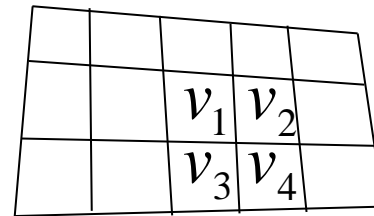
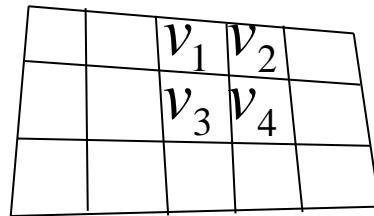
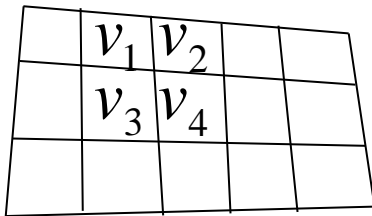

CONTROL_ALE

*CONTROL_ALE

DCT **NADV** **METH** **AFAC** **BFAC** **CFAC** **DFAC** **EFAC**
START **END** **AAFAC** **VFAC** **PRIT** **EBC** **PREF** **NSIDEBC**

DCT =-1 Activates important fixes to advection

NADV Number of time steps between mesh smoothing and advection

METH Advection method (1=Donor Cell, 2=van Leer, 3=Donor Cell with energy conservation)

AFAC =-1 no mesh smoothing

BFAC mesh smoothing parameters

CFAC

DFAC

START Birth time for ALE

END Death time for ALE

AAFAC (obsolete)

VFAC Void factor for element formulation 12

PRIT Pressure iteration flag.

EBC Flag for automatically applied BC's along the boundary of the ALE domain

PREF Reference pressure (applied to all free boundaries of the ALE mesh)

Multi-material Formulation -- Volume Fraction

- The multi-material ALE formulation is a method where two or more different materials can be mixed within the same mesh.
- Each element in the ALE mesh contains a certain volume fraction of each material. Boundaries are defined internally as the region where the interpolated nodal averaged volume fraction equals 50%.

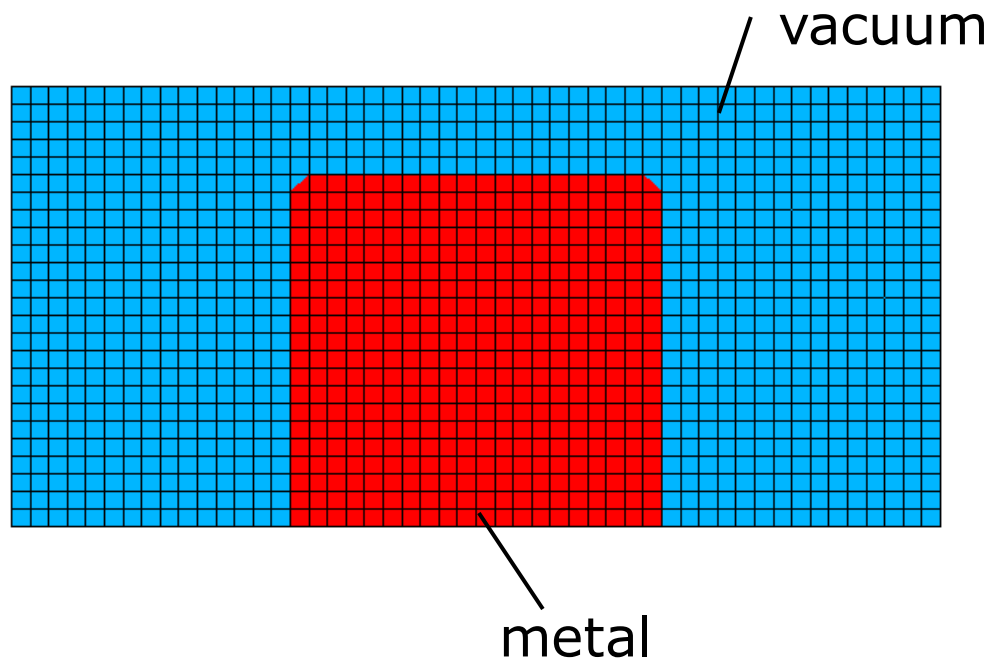

Composite stress tensor

The composite stress, σ^* , is the volume fraction weighted average of the individual material group stresses, σ_k $k = [1, \text{nmat}]$.

$$\sigma^* = \sum_{k=1}^{\text{nmat}} \eta_k \sigma_k \quad \sum_{k=1}^{\text{nmat}} \eta_k = 1$$

3 different materials

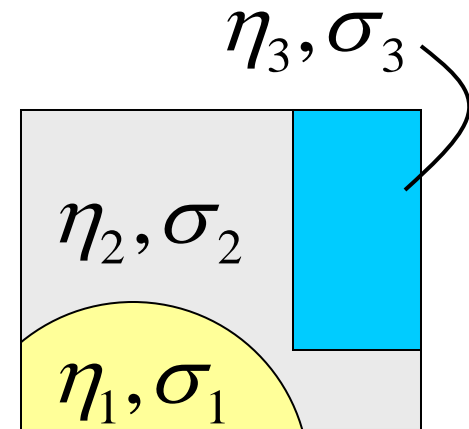
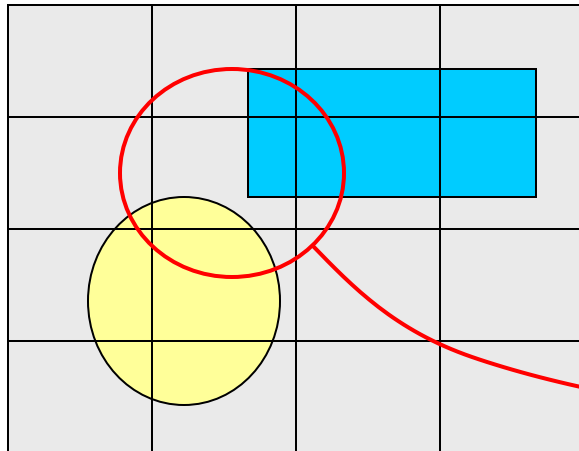

Volume filling at initial stage

***INITIAL_VOLUME_FRACTION**

EID	VF1	VF2	VF3	VF4	VF5	VF6	VF7
------------	------------	------------	------------	------------	------------	------------	------------

EID	Element ID						
------------	------------	--	--	--	--	--	--

VF1	Volume fraction of multi-material group 1						
------------	---	--	--	--	--	--	--

VF2	Volume fraction of multi-material group 2						
------------	---	--	--	--	--	--	--

VF3	Volume fraction of multi-material group 3, etc.						
------------	---	--	--	--	--	--	--

This command is used to allow initially mixed elements.

conventional meshing

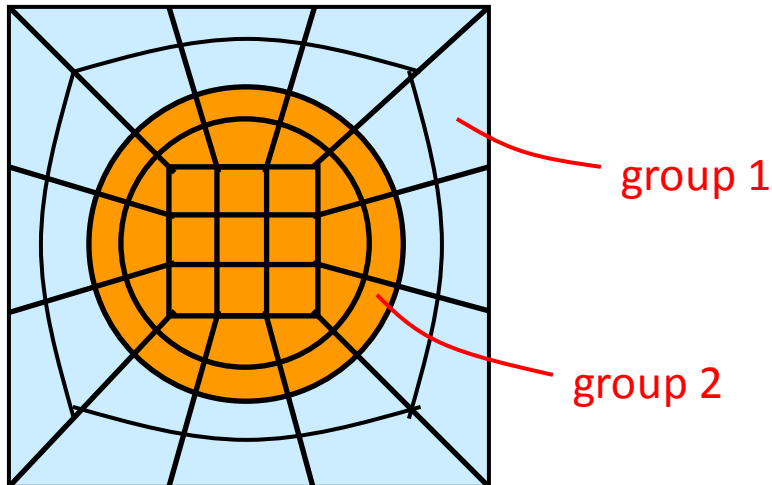

*INITIAL_VOLUME_FRACTION

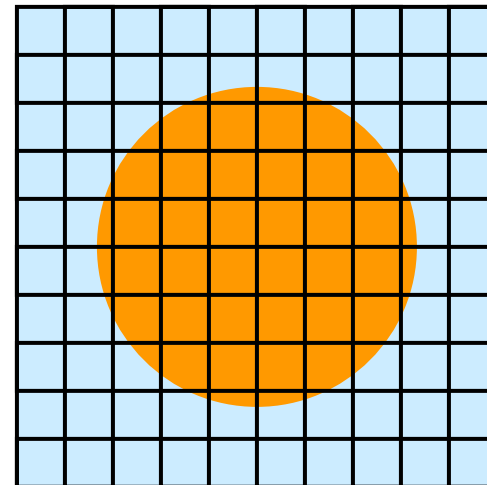

Volume filling at initial stage

*INITIAL_VOLUME_FRACTION_GEOMETRY

FMSID **FMIDTYPE** **BAMMG** **NTRACE**
CONTTYP **FILLOPT** **FAMMG**
- geometry description -

FMSID ALE mesh set ID
FMIDTYPE ALE mesh ID type (0=part set, 1=part)
BAMMG Background multi-material group ID
NTRACE Number of sampling points in calculating filling volume
CONTTYP Geometry type (1=shell, 2=segment, 3=plane,
 4=cylinder, 5=box, 6=sphere)
FILLOPT Geometry head/tail (0=head, 1=tail)
FAMMG Multi-material group ID to be filled in

Each **CONTTYP** has its own geometry description, see keyword manual for details.

This command is used to generate initial volume fractions for arbitrary geometries. A body is defined as combinations of simple primitives and shell/segment geometries.

Interface reconstruction

As mass is fluxing between elements, the initially sharp material boundaries smear out. That is, there is a transition region where the volume fractions drop from 1 to 0. ← Without interface reconstruction

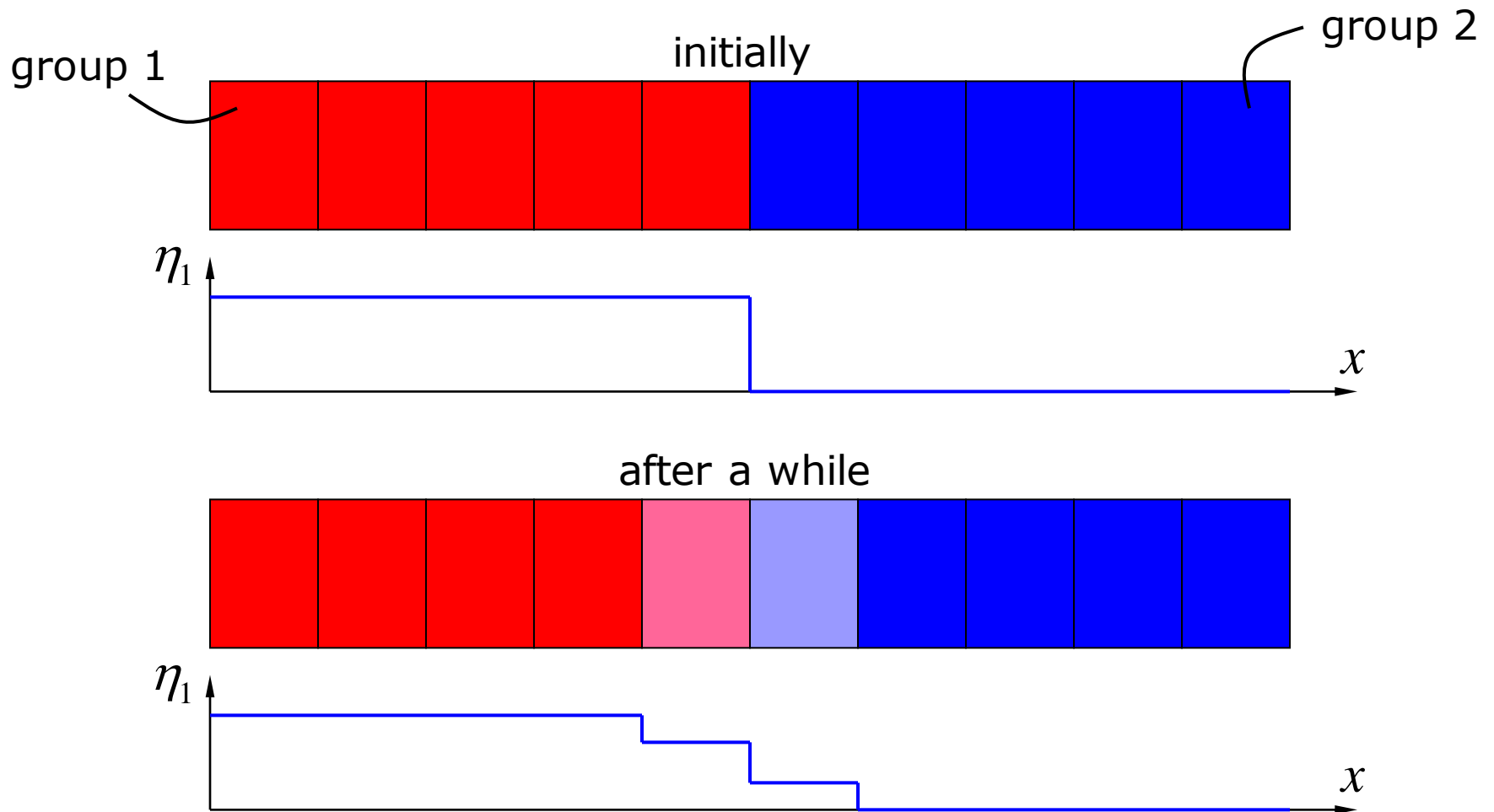

Interface reconstruction

We want to keep the transition region as sharp as possible. For this reason, the volume fractions are advected differently from the other history variables. That is, we don't use the Donor cell or van Leer schemes to estimate the volume fraction flux.

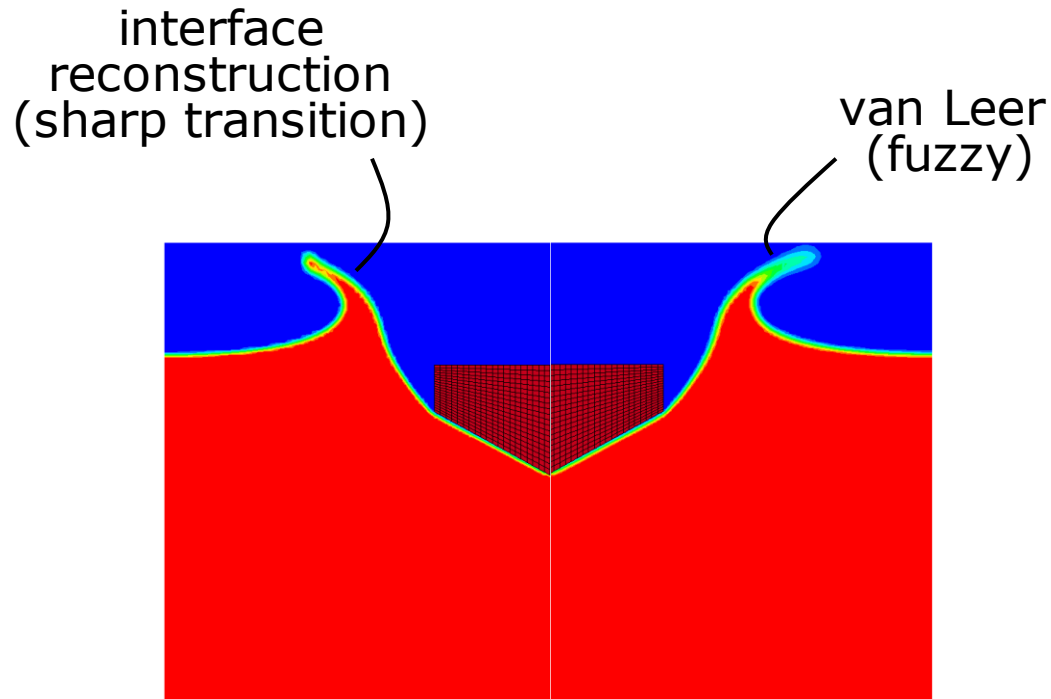

Interface reconstruction

With the interface reconstruction, mixed elements are cut with a plane, separating the location of the different materials. The plane orientation is based on the gradient of the volume fraction field.

example with two materials

element before mesh smoothing

assumed distribution of materials

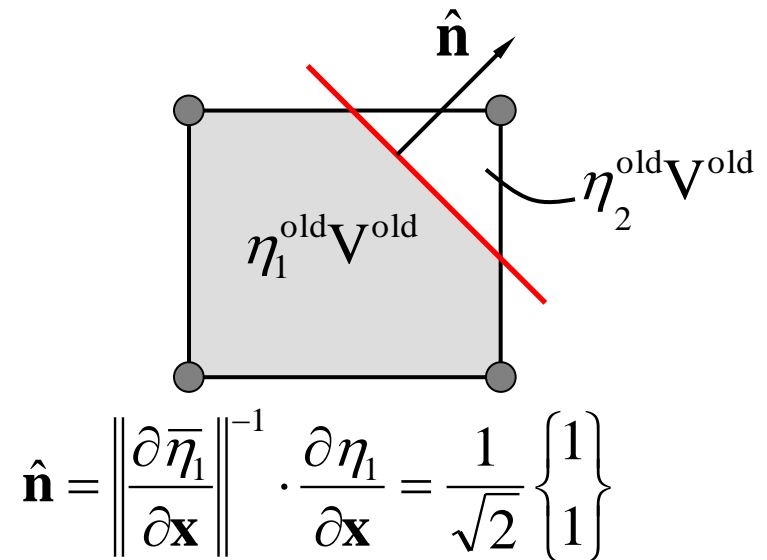
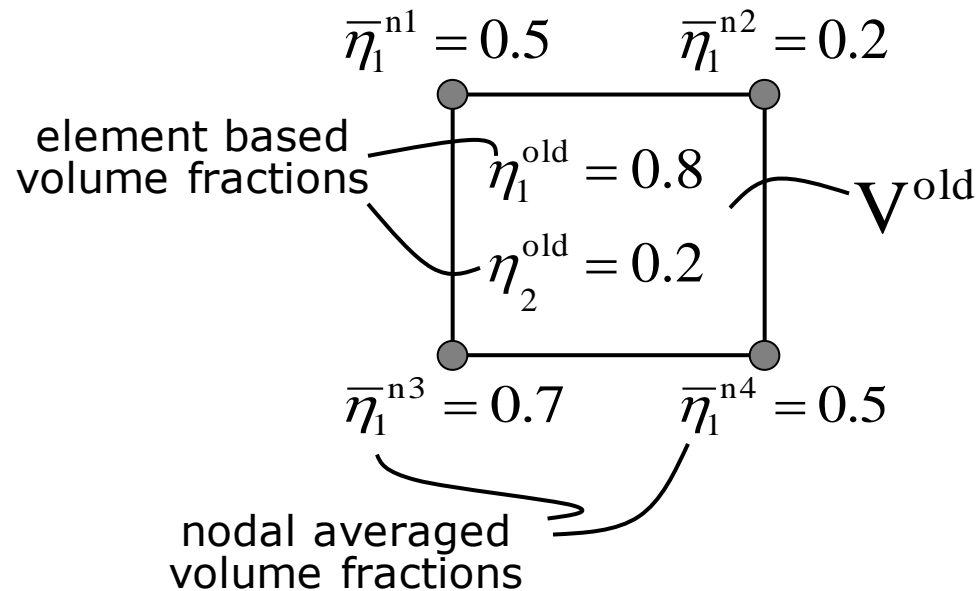

Interface reconstruction

The element is moved during mesh smoothing. The volume fractions are updated based on the assumed material distribution.

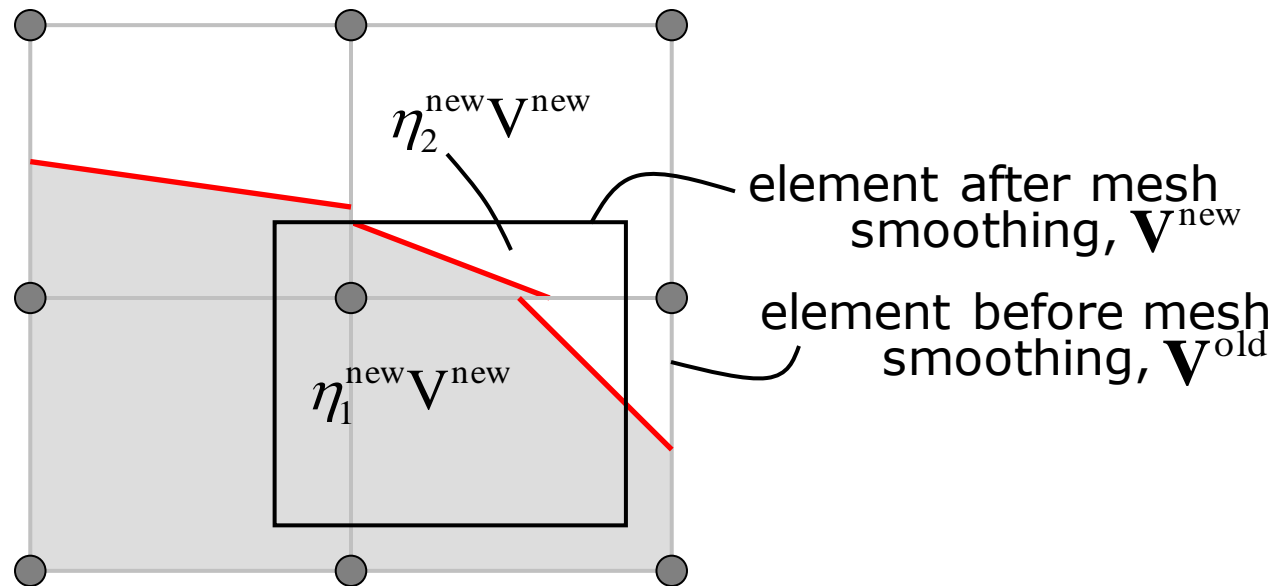

ALE In Depth

*PART in ALE

- PART definition is clear for Lagrangian entities as their geometric mapping always remain the same. It includes:

Element Formulation (*SECTION_SOLID)

Material definition (*MAT+*EOS+*HOURGLASS)

Mesh (*ELEMENT)

- For ALE simulations, mesh doesn't move with the Eulerian/ALE entities. This has caused considerable confusions and modeling errors.

An element is no longer associated with only one material. In stead, an element could be occupied by all the defined ALE multi-materials.

Element volume fractions determines

1. The volume of each multi-material
2. The multi-material interface

*PART in LAGRANGIAN

PART=SECTION_SOLID+MATERIAL+MESH

- SECTION_SOLID: Element formulation
- MATERIAL: MAT+EOS+HG+BV
- MESH: 2nd field in each *ELEMENT entry

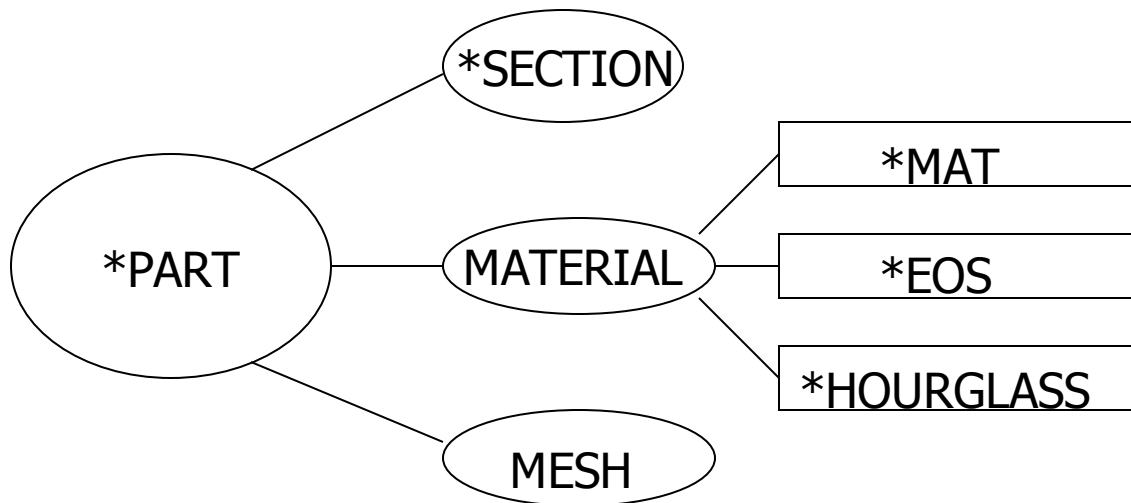

*PART in ALE

PART=MATERIAL

- SECTION_SOLID: Always eleform=11
- MATERIAL: MAT+EOS+HG+BV
- MESH: Always shared by all AMMGs

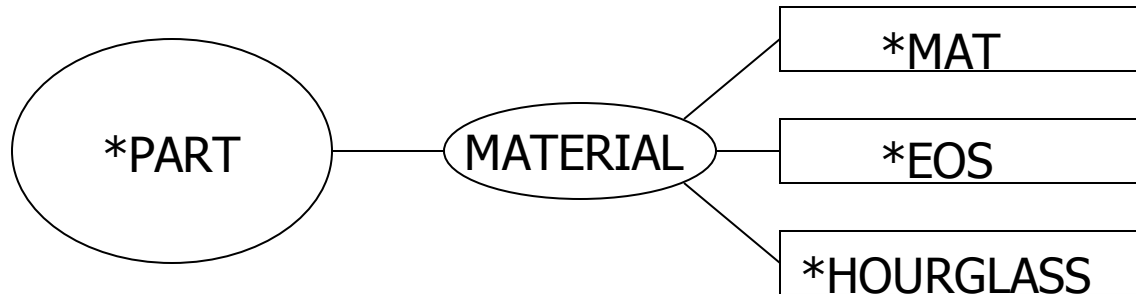

*PART in ALE

*PART only serves as a material wrapper to be used in
*ALE_MULTI-MATERIAL_GROUP

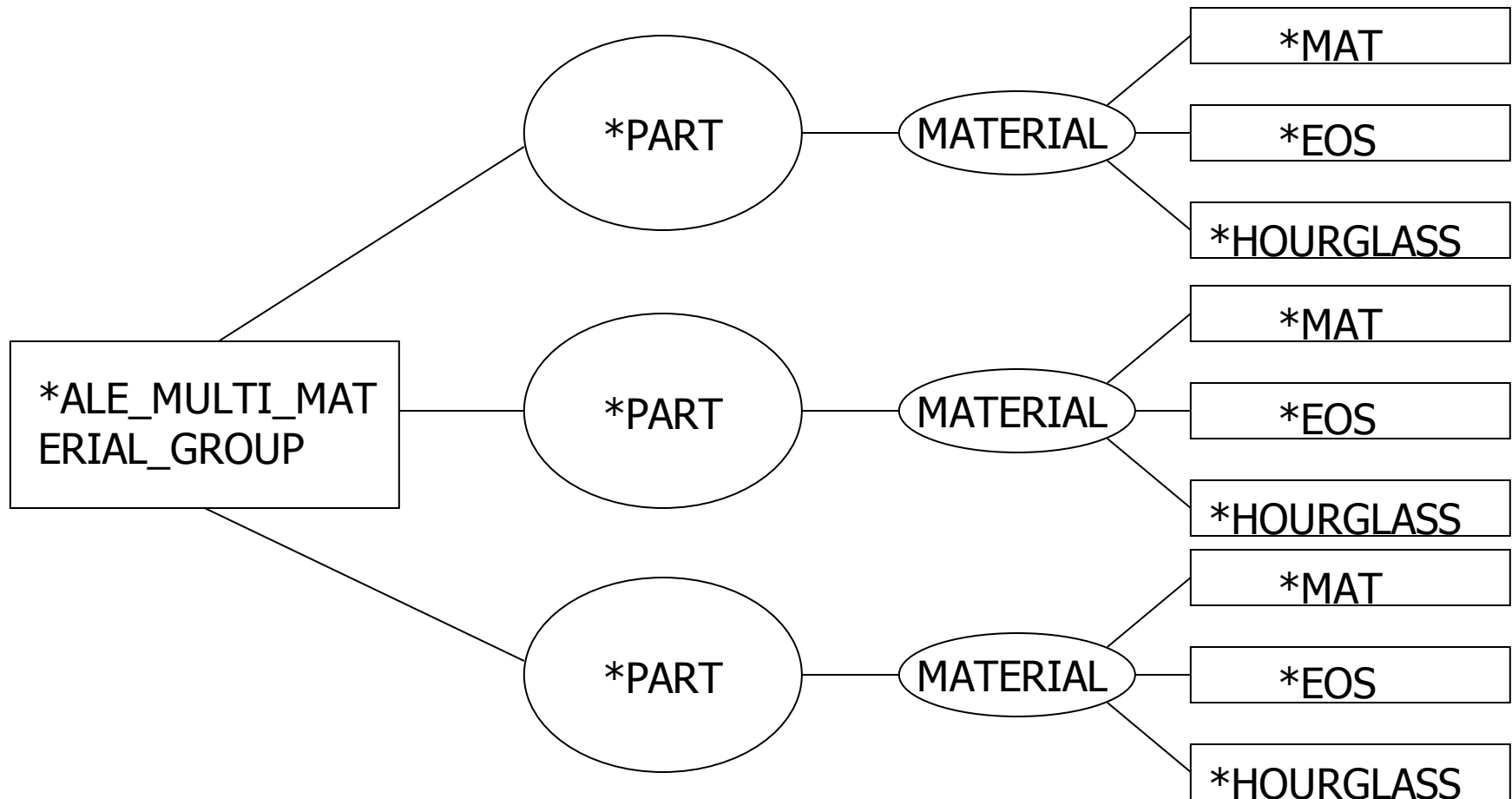

Volume Flux

We need to differentiate three kinds of configurations.

1. Initial configuration at timestep n
2. Deformed configuration at timestep $n+1$ Lagrange step
3. Final configuration at timestep $n+1$, i.e. the new mesh to be mapped to
 - ALE: new mesh after mesh motion (expansion, translation, rotation, etc)
 - Eulerian: = initial configuration

Volume Flux

- Volume flux through the six faces of an element is calculated.

No corner flux

Pros: cost saving; can handle multi-materials; compatible with half-index shift

Cons: direction biased, shear

- Swept-through algorithm

Volume flux = the volume the segment swept through

Volume Flux

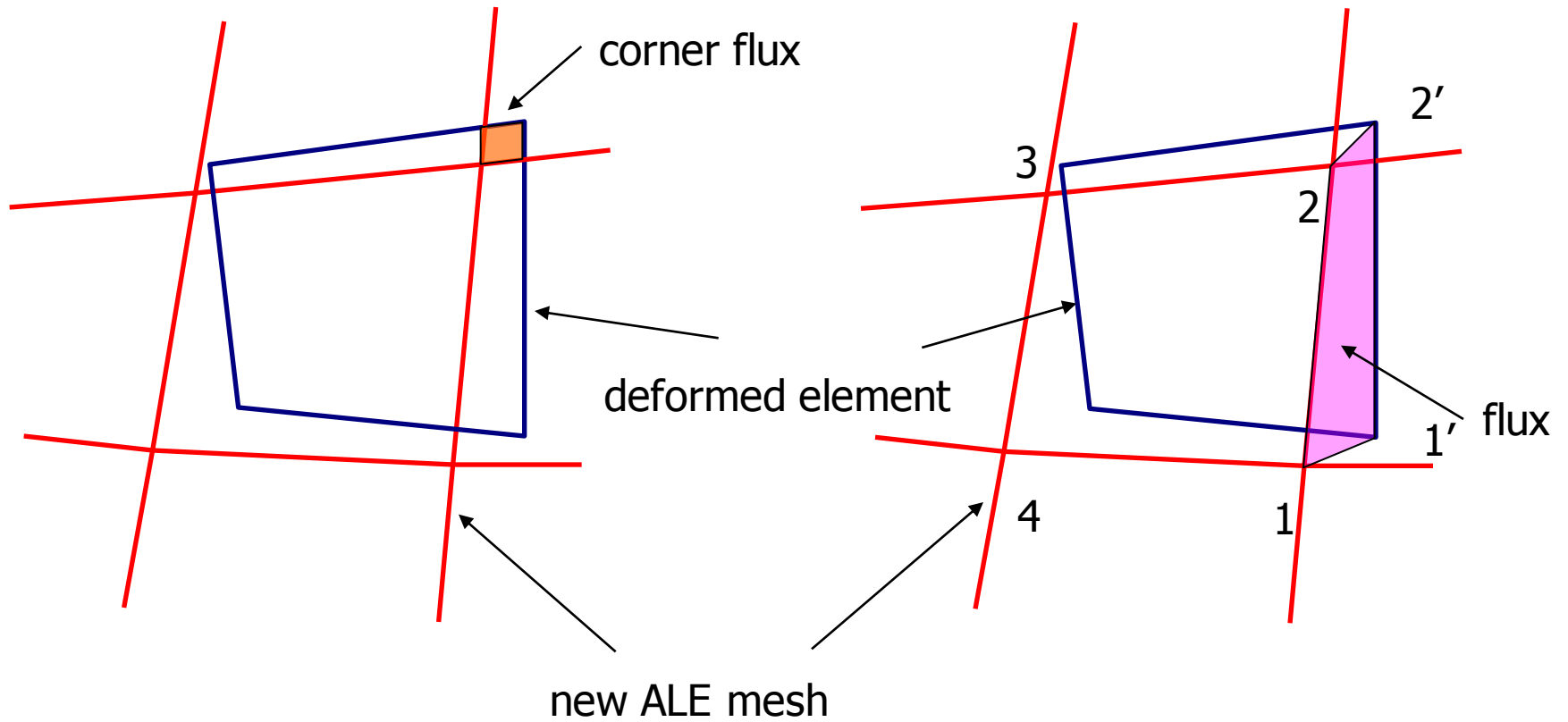

Volume Flux

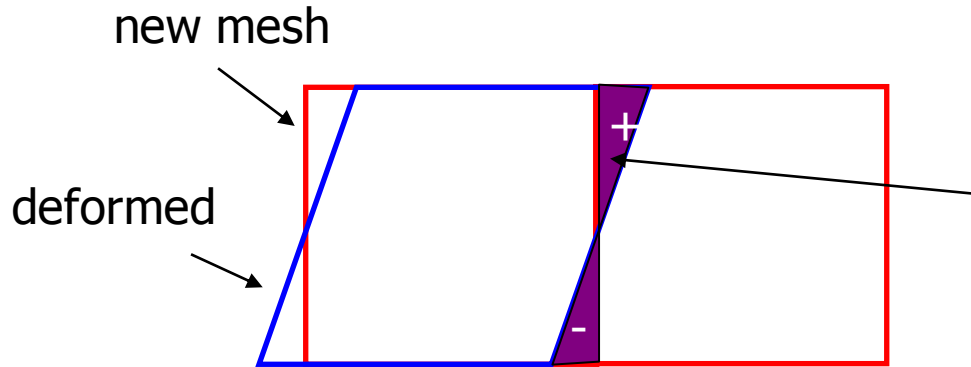

For an element undergoes pure shear deformation, the flux through the element surface calculated using swept-through method is zero.

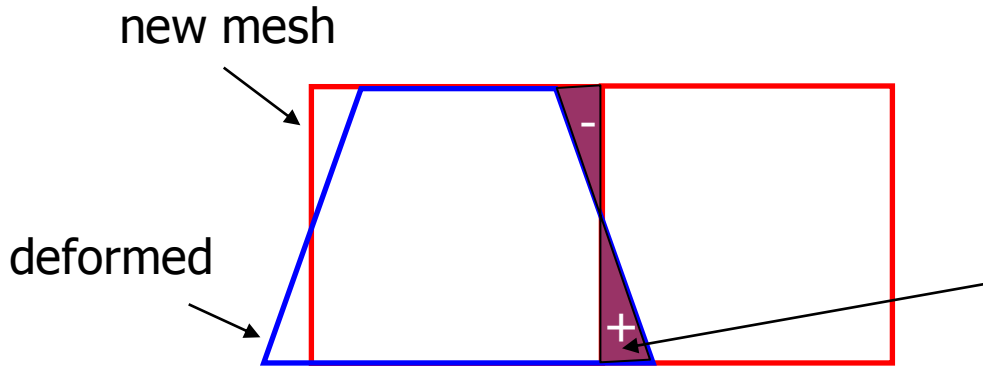

For an hourglass deformation, the flux through the element surface calculated using swept-through method is zero.

Averaging history variables

Problems:

- Some history variables are used as flags/switches.
 - damage flag
 - loading/unloading flag
 - loading path flag
 - previous position in the load curve
- Some history variables are nonlinear to strain/stress.
 - exponential, logarithm
 - quadratic/cubic
- Nonlinear material
 - strain/stress relationship is not linear. Averaging both gives us contradictory stress/strain pair.
- Stress update
 - Radial return assumes old stress states either inside or on the yielding surface. Volumetric averaging can not guarantee this.
- Dissipation
 - Internal energy loss due to advection

Interface Reconstruction

With the interface reconstruction, mixed elements are cut with a plane, separating the location of the different materials. The plane orientation is based on the gradient of the volume fraction field.

example with two materials

element before mesh
smoothing

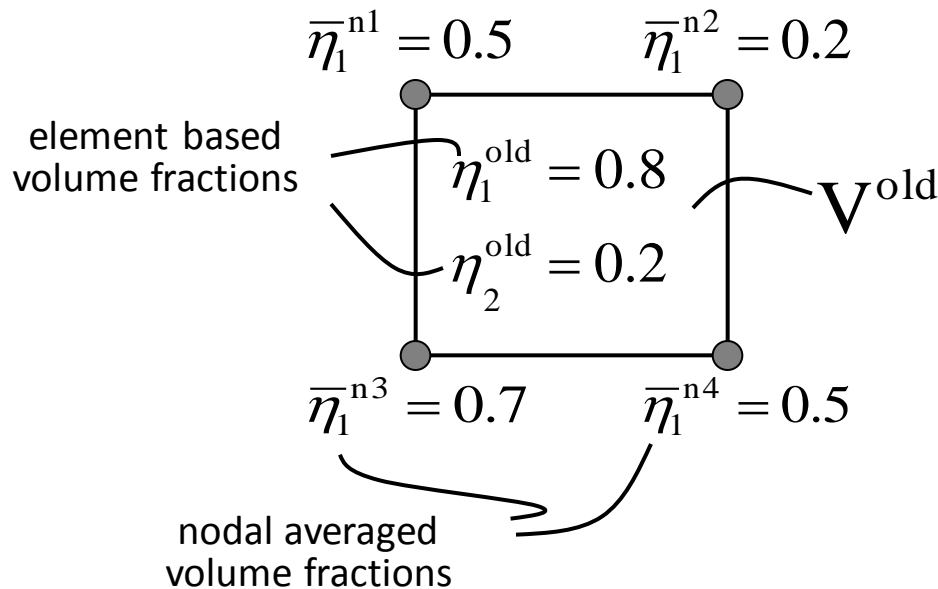

assumed distribution
of materials

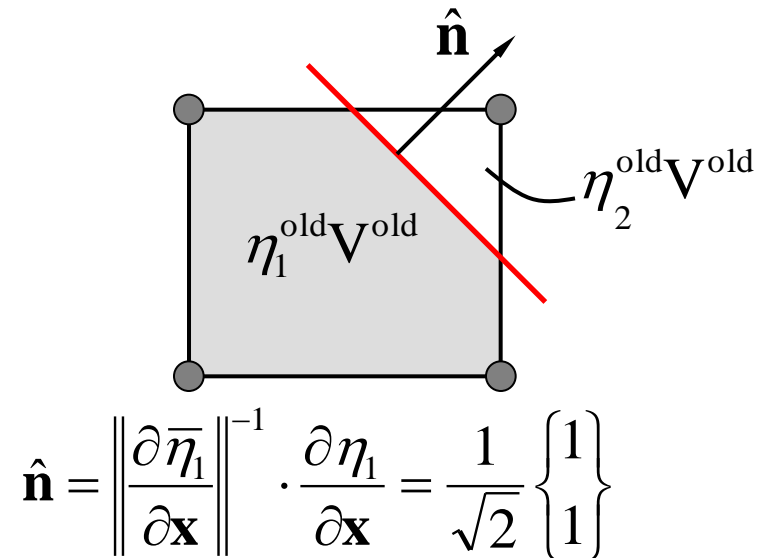

Interface Reconstruction

1. Element volume fraction \rightarrow Nodal volume fraction
2. Gradient of nodal volume fraction \rightarrow interface normal
3. Move the cut interface until the volume cut is equal to the element volume fraction
4. The process repeats for each AMMG in the order it is defined in the `*ALE_MULTI-MATERIAL_GROUP`

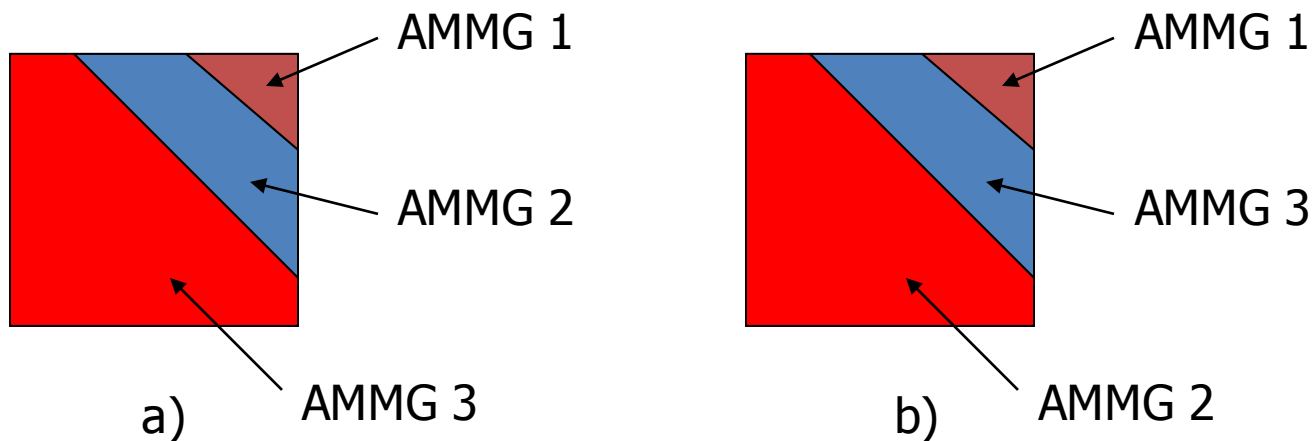

Interface Reconstruction

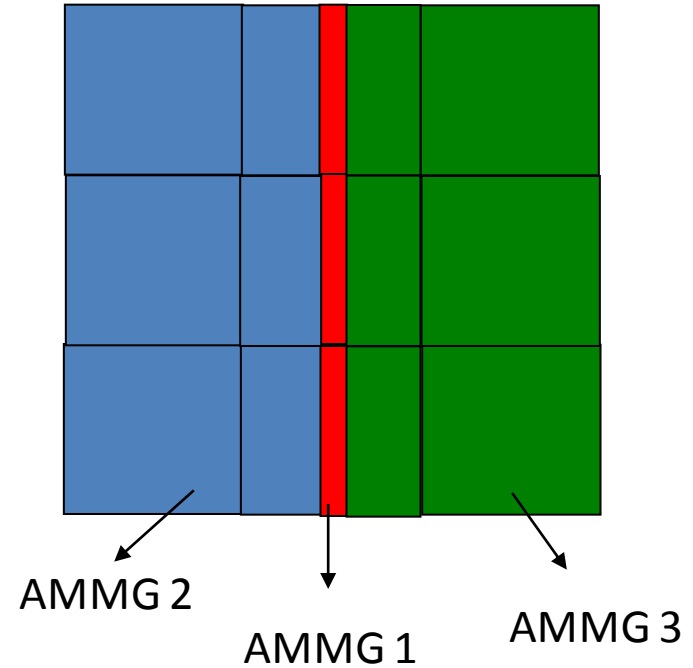
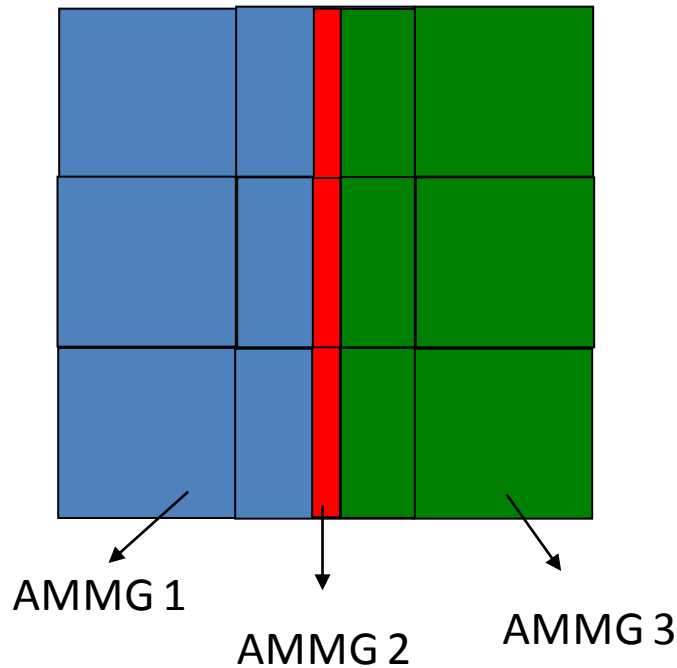

The above shows two different setup for *ALE_MULTI-MATERIAL_GROUP.
Which one is right? Why?

Fluid Structure Interaction

Coupling

- Construct the Lagrange interface
- Construct the fluid interface
- Attach a penalty spring
- Measure penetration
- Apply penalty force

Structure Interface

- We check at specific locations on the structure to see if fluid is penetrating at those places.
- Those points are called coupling points (on the structure side).
- The density of those points are controlled by NQUAD.
- In any one structural segment, there are $NQUAD \times NQUAD$ number of coupling points.

Structure Interface

*CONSTRAINED_LAGRANGE_IN_SOLID							
SLAVE	MASTER	SSTYP	MSTYP	NQUAD	CTYPE	DIREC	MCOUP
		PFAC		FRCMIN	NORM	NORMTYP	
			ILEAK	PLEAK			

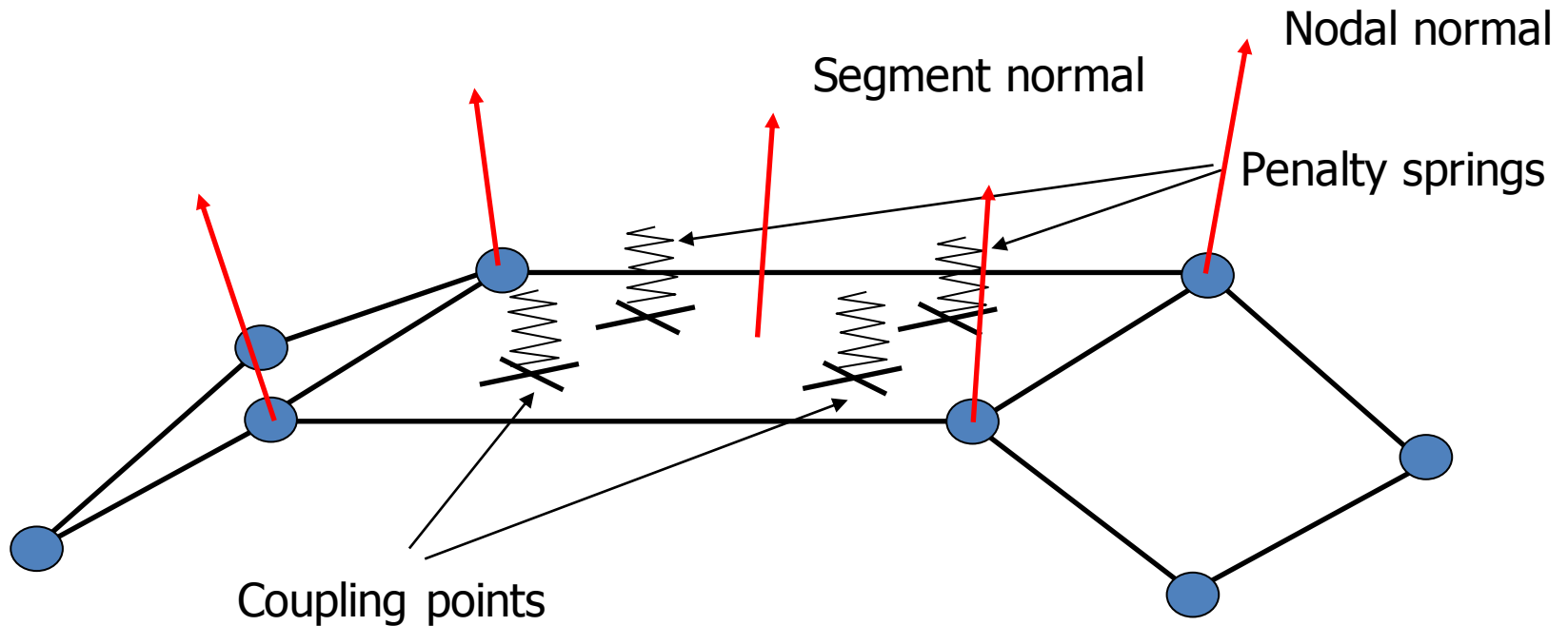

Structure Interface

*CONSTRAINED_LAGRANGE_IN_SOLID							
SLAVE	MASTER	SSTYP	MSTYP	NQUAD	CTYPE	DIREC	MCOUP
		PFAC		FRCMIN	NORM	NORMTYP	
			ILEAK	PLEAK			

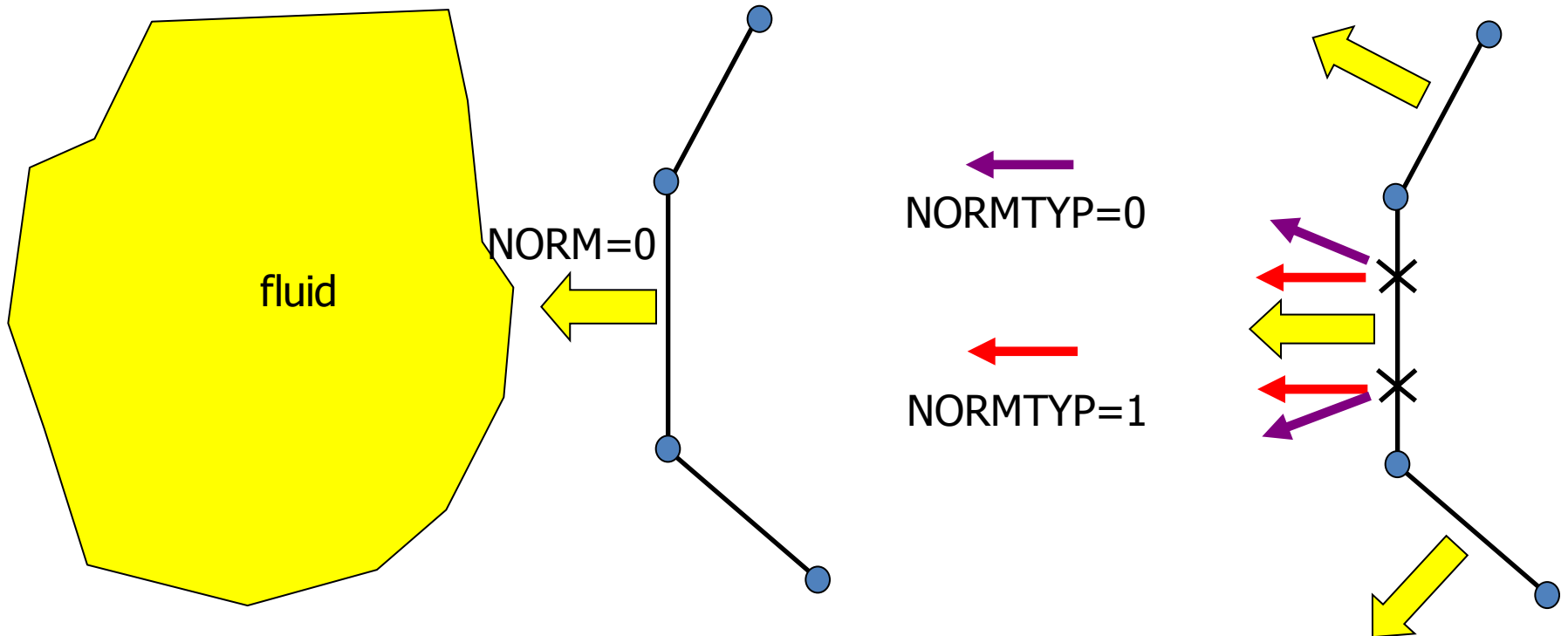

Fluid Interface

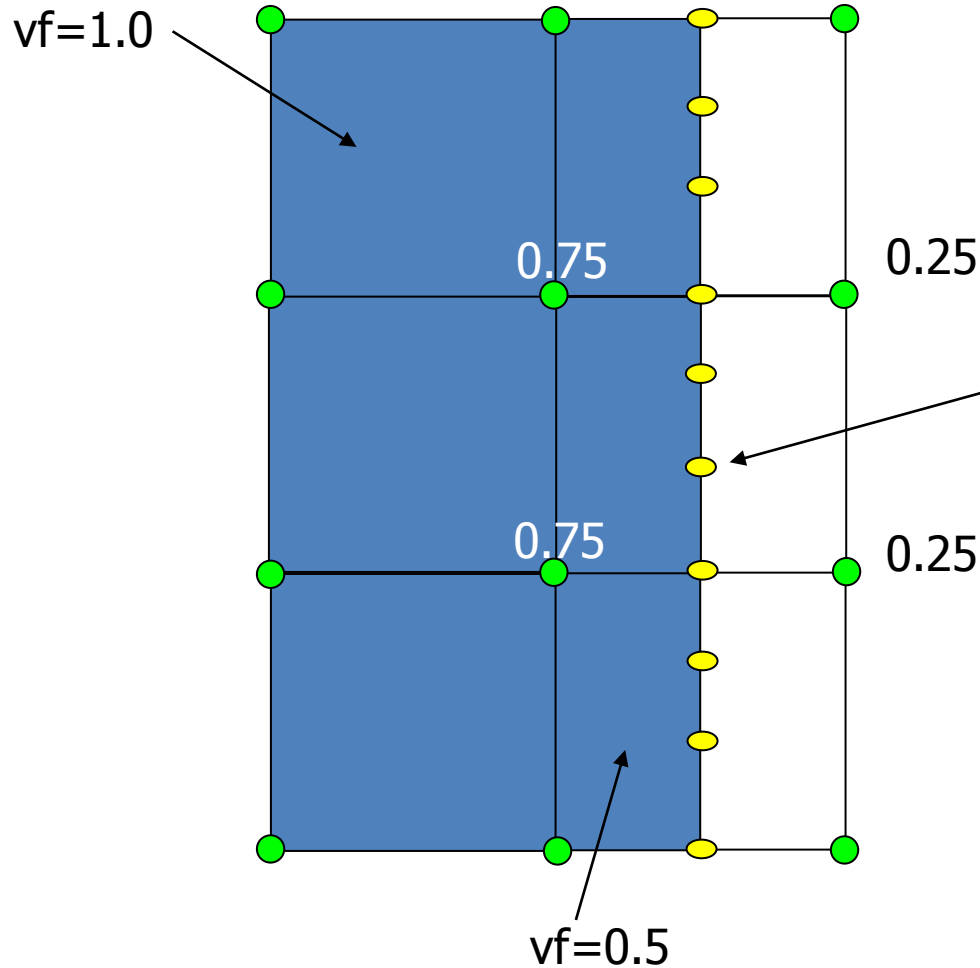

Fluid interface:
 $vf=0.5$ surface

$$vf = \sum_I N_I vf_I = 0.5$$

- Node
- Point on fluid interface

Fluid Interface

*CONSTRAINED_LAGRANGE_IN_SOLID							
SLAVE	MASTER	SSTYP	MSTYP	NQUAD	CTYPE	DIREC	MCOUP
		PFAC		FRCMIN	NORM	NORMTYP	
			ILEAK	PLEAK			

FRCMIN – start the coupling at $vf = \text{FRCMIN}$ interface

- o =0.5 start normally at $vf = 0.5$ interface
- o <0.5 start the coupling little earlier to avoid leakage

ILEAK=2, FRCMIN default value is 0.3.

Suggestion:

- o use default value of 0.5 with ILEAK=0
- o use default value of 0.3 with ILEAK=2

Spring

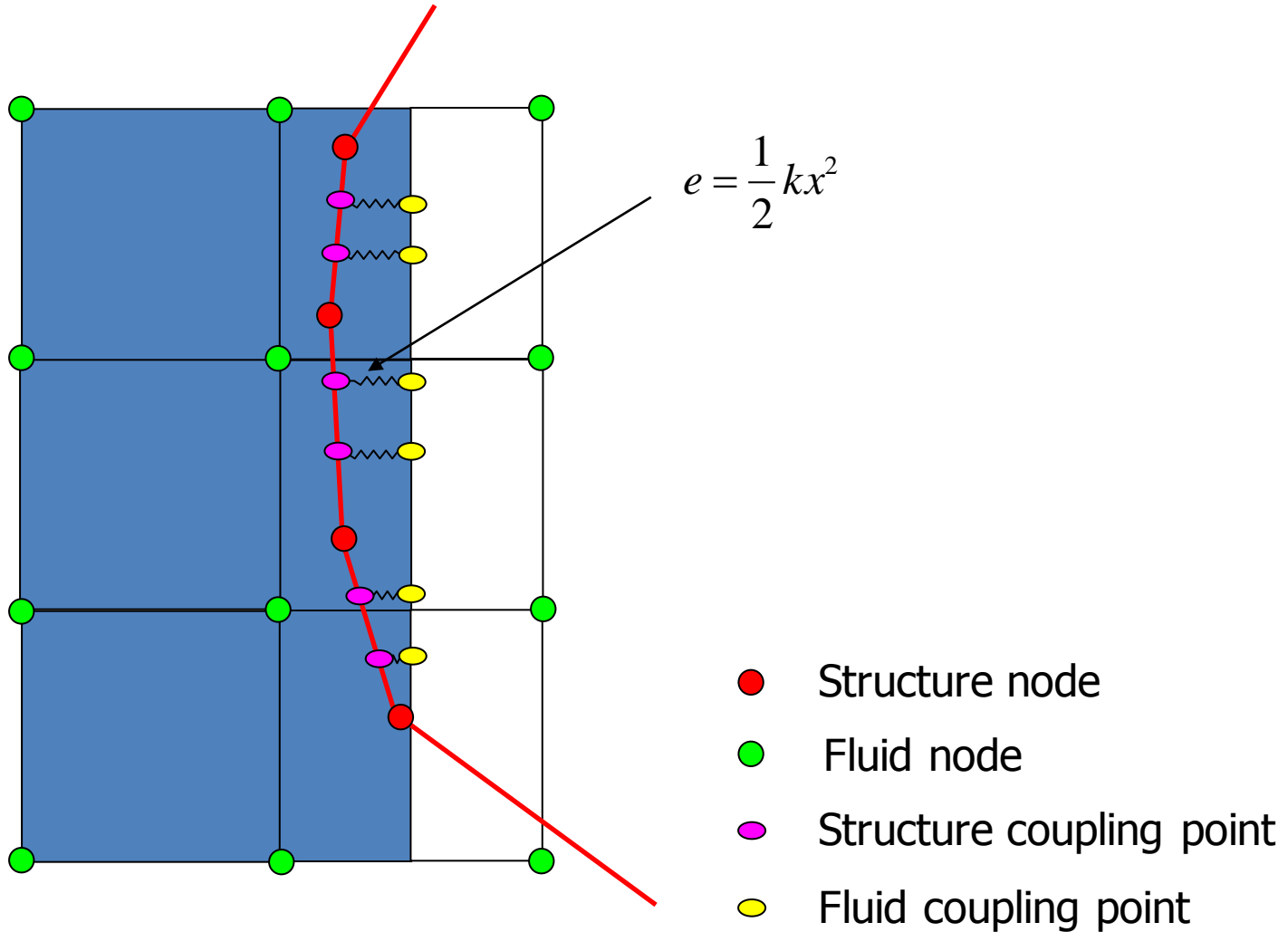

Penalty Force

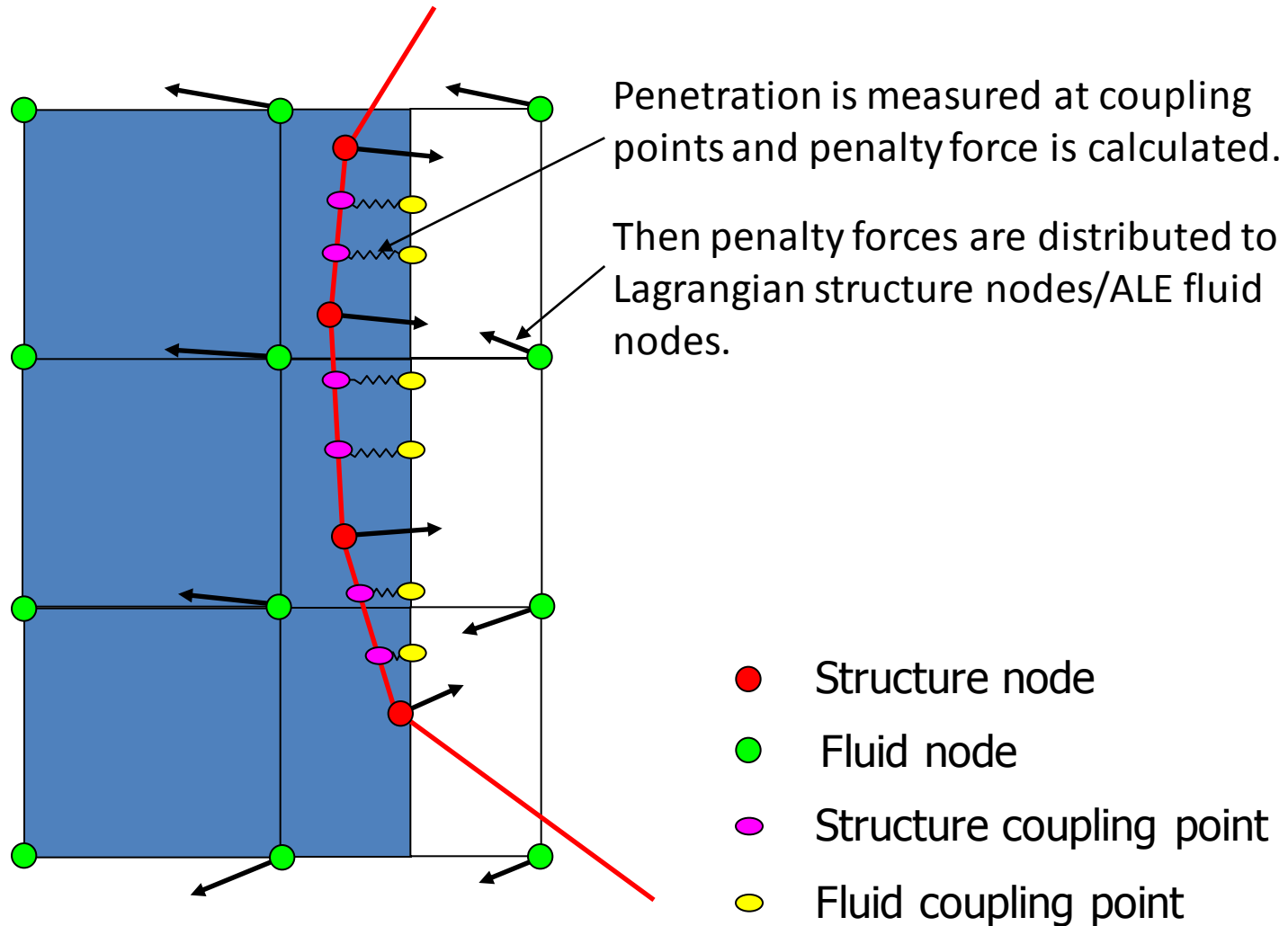

Leakage

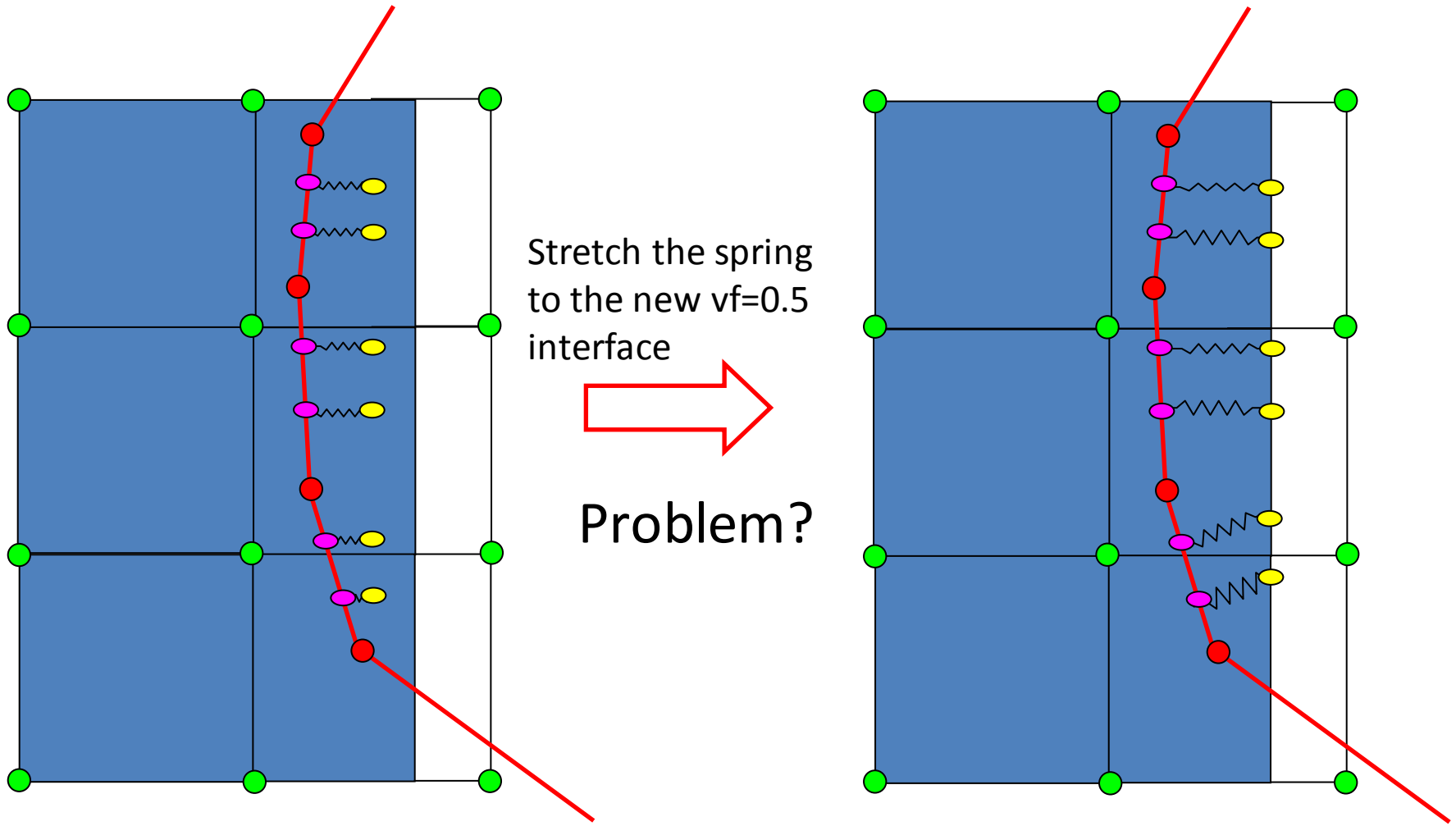

- Structure node
- Fluid node
- Structure coupling point
- Fluid coupling point

Leakage

*CONSTRAINED_LAGRANGE_IN_SOLID

SLAVE	MASTER	SSTYP	MSTYP	NQUAD	CTYPE	DIREC	MCOUP
		PFAC		FRCMIN	NORM	NORMTYP	
			ILEAK	PLEAK			

ILEAK – leakage control flag

o =1: leakage control on

o =2: energy conservation on

PLEAK – spring stretch scale factor

o =0.1: each time step stretch 10% of the total distance between old and new fluid interface.

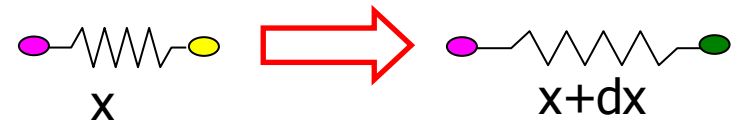

● Structure coupling point

● Old fluid coupling point

● New fluid coupling point

$$\Delta e = e^{new} - e^{old} = \frac{1}{2}k(x + dx)^2 - \frac{1}{2}kx^2$$

MCOUP, DIREC

*CONSTRAINED_LAGRANGE_IN_SOLID							
SLAVE	MASTER	SSTYP	MSTYP	NQUAD	CTYPE	DIREC	MCOUP
		PFAC		FRCMIN	NORM	NORMTYP	
			ILEAK	PLEAK			

DIREC – Coupling direction

- o =1: Compression and tension (both sides)
- o =2: Compression only (Structure normal direction)
- o =3: All directions (rare cases)

MCOUP – Fluids to be coupled

- o =0: All fluids
- o =1: highest density one
- o = -N: N is the ID in *SET_MULTI-MATERIAL_GROUP_LIST

Penalty Stiffness

*CONSTRAINED_LAGRANGE_IN_SOLID							
SLAVE	MASTER	SSTYP	MSTYP	NQUAD	CTYPE	DIREC	MCOUP
		PFAC		FRCMIN	NORM	NORMTYP	
			ILEAK	PLEAK			

PFACT– Penalty stiffness

o =0.1: fractional stiffness factor

o =-N: N user-defined load curve ID

$$k = pfact \cdot \frac{m}{\Delta t^2}$$

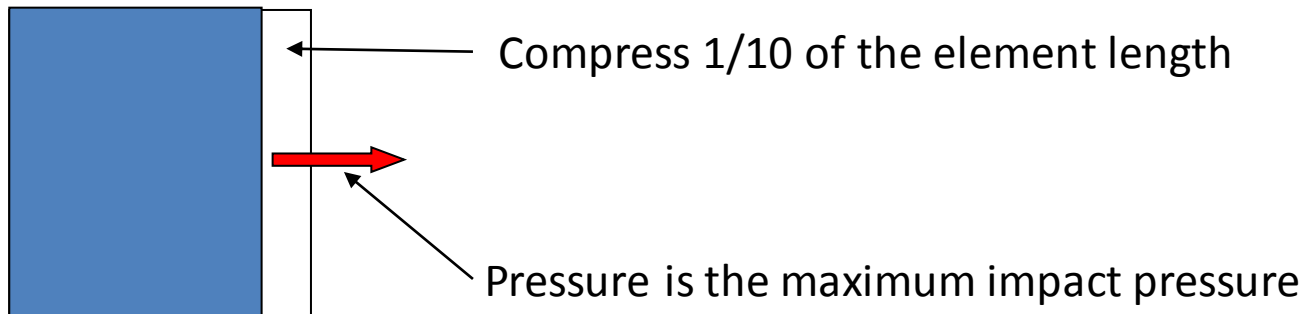

Thank You